

manual for:

PRM100-

140-

175-

250-

265

this manual is offered to you by:



DINTRA TRANSMISSIES V.O.F.

Keizerswoert 30 - 3881 LE - Putten - NL

Tel.: +31(0)341-353712 - Fax +31(0)341-360046

www.dintra.com

info@dintra.nl

PRM 100-140-175-250-265.

NEWAGE

DINTRA

PRM
MARINE GEARBOX



workshop manual

PRM HYDRAULIC GEARBOXES

PRM 100
PRM 140S
PRM 140T
PRM 175
PRM 250
PRM 265S
PRM 265T

Intro

WORKSHOP MANUAL

PUBLICATION NO.10/4

FOURTH EDITION

Issued by

**NEWAGE ENGINEERS LIMITED
TRANSMISSIONS DIVISION**

BARLOW ROAD COVENTRY CV2 2LD ENGLAND

Telephone 0203-617141

Telex 31333 Cables 'Supagears' Coventry

Effective from October 1974

Price 75p nett

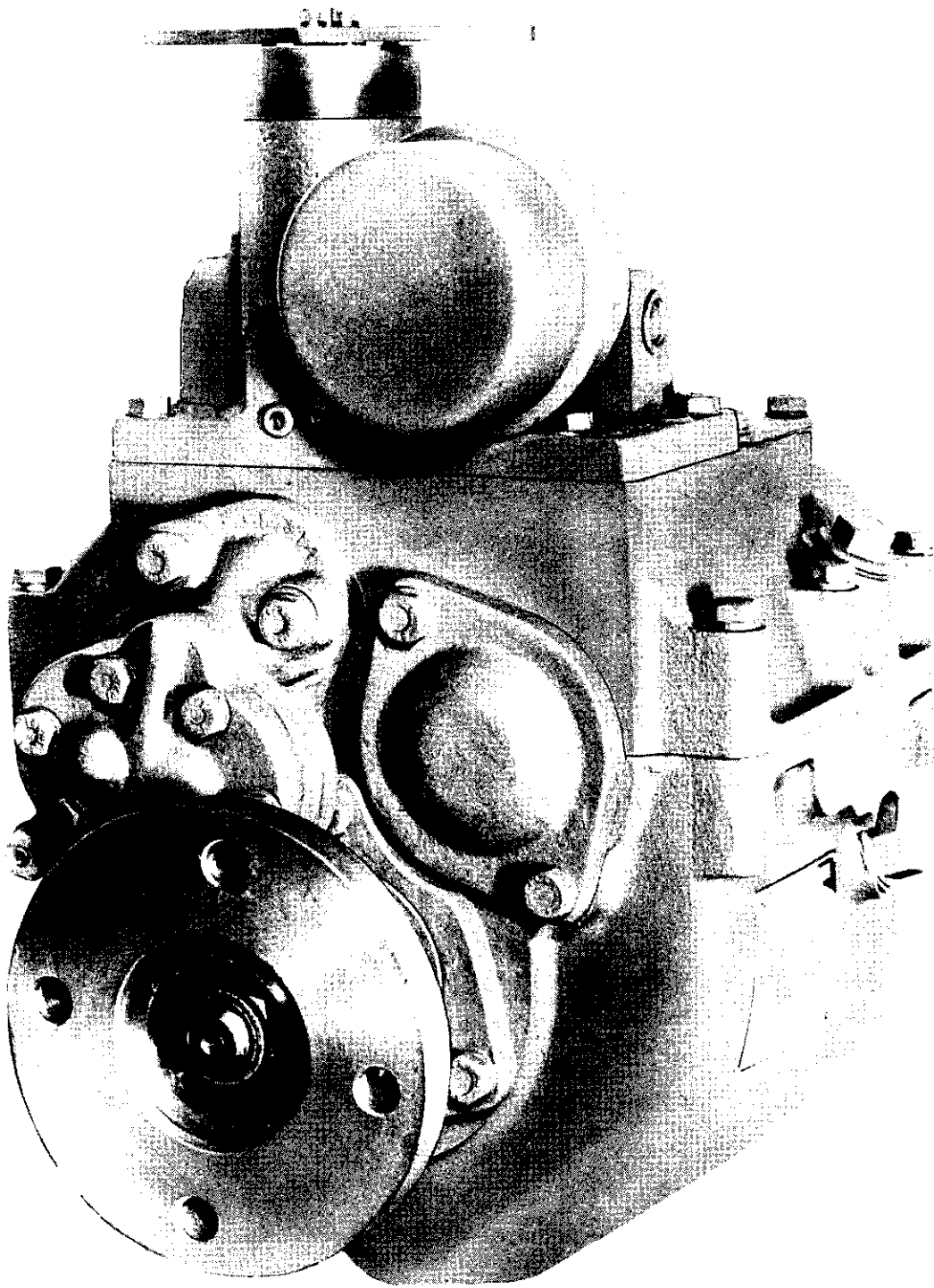

Fig. 1 - PRM Gearbox

CONTENTS

	Page
Foreword	3
General Information	3
Claims under warranty	3
Service parts	3
General data	5
Introduction	6
Construction	6
Oil pump	6
Valve block	6
Installation	7
Changing the mounting position	10
Recommended lubricants	13
Operation	14
Hydraulic action	14
Lubrication	16
Emergency operation	16
Routine Maintenance	16
Initial servicing - after 25 running hours	16
General maintenance	16
Removing the input shaft and layshaft assemblies	18
Input clutch shaft	18
Oil seal	18
Drive end bearing	18
Clutch assembly	19
Clutch gear	19
Drive pinion	20
Non-drive end bearing	20
Piston rings and feeder	20
Layshaft	21
Drive end bearing	21
Clutch assembly-drive pinion and clutch gear	21
Non-drive end bearing	21
Piston rings and feeder	21
Replacing the input shaft and layshaft assemblies	21
Output shaft	21
Front bearing and output gear	22
Oil seal	22
Rear bearing	22
Valve block	22
Low pressure relief valves	22
Control valve	22
High pressure relief valve	22
Spare Parts Ordering	23
Parts List	25

ILLUSTRATIONS

	Fig.	
PRM gearbox	1	
PRM100 and 140(S) & (T) Installation details	2	
PRM175, 250 and 265 (S) & (T) Installation details	3	
Basic installation positions	4	
Adaptor plate drilling	5	
Internal layout diagram - standard gearbox	6	
Oil flow diagram	7	
Gearbox sectional arrangement	8	
Piston rings - fitting procedure	9	
Gearbox top view	10	
Gearbox rear view	11	
Valve block assembly	12	
Clutched shaft assembly - input	} (PRM 100, 175 and 250)	13
Clutched shaft assembly - layshaft		14
Gearcase and output shaft assembly	15	
Clutched shaft assembly - input	} (PRM 140 and 265)	16
Clutched shaft assembly - layshaft		17

FOREWORD

The workshop manual has been prepared to assist the operator or user of PRM marine gearboxes and also to enable the skilled service engineer to undertake more detailed maintenance and overhaul.

The manual is divided into three basic sections; operation, maintenance and service parts respectively. Detailed breakdown of text and illustration references are shown on the contents page.

GENERAL INFORMATION

PRM hydraulic marine gearboxes will give trouble-free service provided they are correctly installed, aligned and maintained. In the event of failure, the engine distributor who supplied the gearbox, or his local dealer, should be informed; where this is not possible, Newage Engineers Limited, or the distributor for the area, should be notified. In all communications, verbal or otherwise the model and serial number of the gearbox should be quoted.

CLAIMS UNDER WARRANTY

Claims for the replacement of parts under warranty must always be submitted to the distributor who supplied the gearbox; if this is not possible, application may be made to the nearest distributor or dealer, who must, however, be advised of the supplier's name and address.

SERVICE PARTS

The comprehensive illustrated parts list at the end of the book gives full information and ordering procedures.

GENERAL DATA

PRM100 and PRM140 (S & T)

Input Torque Capacity				
PRM100	100 lbf.ft (14 kgm) continuous, ahead or astern
PRM140 (S & T)	140 lbf.ft (19.4 kgm) continuous, ahead or astern
Input Speeds				
	Up to 3,600 rev/min continuous, 4,000 rev/min intermittent.
Input Rotation				
	Accommodates either clockwise (right-hand) or anti-clockwise (left-hand) rotating engines.
Output Rotation				
	Either clockwise or anti-clockwise as required, irrespective of gear ratio or input rotation.
Gear Ratios				
	Direct drive (1:1), or integral reduction of 1.96:1 or 2.94:1.
Oil Capacity				
Positions VR and VL	2½ pints (1.4 litres) approx.
Positions HR and HL	3 pints (1.7 litres) approx.
Oil Pressure				
Working	180 - 210 P.S.I. (12.7 - 14.8 kg/cm ²)
In neutral	60 P.S.I. (4.2 kg/cm ²)
Oil Temperature (Working)				
	50°C - 80°C dependent on ambient temperature. Maximum permissible working temperature 90°C.
Thrust Capacity - Both Models (ahead and astern)				
Direct Drive	1700 lbf (771 kg)
2:1	1900 lbf (862 kg)
3:1	2700 lbf (1225 kg)
Approx. Dry Weight				
PRM100	120 lb (54 kg)
PRM140 (S & T)	120 lb (54 kg)
Overall Dimensions				
Length	14 in (37.6 cm)
Width	10 in (26.35 cm)
Height	16 in (41.11 cm)
Installation Angle				
	Maximum permissible water line installation angle (fore and aft) : 17°.

PRM175, PRM250 and PRM265 (S & T)

Input Torque Capacity				
PRM175	175 lbf.ft (24 kgm) continuous, ahead or astern.
PRM250	250 lbf.ft (34.5 kgm) continuous, ahead or astern.
PRM265 (S & T)	265 lbf.ft (36.5 kgm) continuous, ahead or astern.
Input Speeds				
	Up to 2,500 rev/min continuous, 3,000 rev/min intermittent.
Input Rotation				
	Accommodates either clockwise (right-hand) or anti-clockwise (left-hand) rotating engines.
Output Rotation				
	Either clockwise or anti-clockwise as required, irrespective of gear ratio or input rotation.
Gear Ratios				
	Direct drive (1:1), or integral reduction of 1.459:1 1.96:1 or 2.94:1.
Oil Capacity				
Positions VR and VL	5½ pints (3.25 litres) approx.
Positions HR and HL	4½ pints (2.5 litres) approx.
Oil Pressure				
Working	180 - 210 P.S.I. (12.7 - 14.8 kg/cm ²)
In neutral	60 P.S.I. (4.2 kg/cm ²)
Oil Temperature (Working)				
	50°C - 80°C dependent on ambient temperature. Maximum permissible working temperature 90°C.
Thrust Capacity - All Models (ahead and astern)				
Direct Drive	2200 lbf (998 kg)
1.5:1	2350 lbf (1066 kg)
2:1	2500 lbf (1134 kg)
3:1	3600 lbf (1633 kg)
Approx. Dry Weight				
PRM175	160 lb (72 kg)
PRM250	166 lb (75 kg)
PRM265(S & T)	168 lb (76 kg)
Overall Dimensions				
Length	14.7/8in (37.78 cm)
Width	10.3/8in (26.35 cm)
Height	17.9/16in (44.60 cm)
Installation Angle				
	Maximum permissible water line installation angle (fore and aft) : 17°.

INTRODUCTION

The PRM hydraulic marine gearboxes are compact, efficient units, capable of transmitting full engine torque continuously through the forward and reverse gears. Rotation of the output shafts can be arranged to be either right hand or left hand, and all gearing is of helical design for quiet operation.

The gearbox casing has been kept free from hydraulic pipes, cylinders and associated components, and the only items mounted externally are the oil pump, oil filter and hydraulic control valves and operating lever.

Connections are provided on the valve block for the mandatory oil cooler and an oil pressure gauge.

CONSTRUCTION

The transmission comprises an input shaft assembly, a layshaft assembly and an output shaft. In all models except the PRM140T and PRM265T the input shaft is splined, the PRM140T and PRM265T incorporate a tapered input shaft.

The input shaft, which is supported by a roller bearing at the drive end and a ball race at the non-drive end, incorporates a drive pinion of the required ratio, an emergency drive engaging ring, forward drive clutch plate assembly, the clutch gear and hydraulically operated piston to actuate the clutch. The layshaft is supported by similar bearings and incorporates a drive pinion of the same ratio, the reverse drive clutch plate assembly, a clutch gear of opposite hand rotation to the one on the input shaft and hydraulically operated piston to actuate the clutch.

The emergency drive engaging ring forms part of the layshaft assembly where the gearbox is fitted to an installation which includes an engine of left-hand crankshaft rotation and a left-hand propeller, or a right hand rotating engine together with a right hand propeller. With twin-engine installations which include one right-hand propeller and one left-hand propeller, the drive ring is fitted to the input shaft in one gearbox and to the layshaft in the other gearbox.

In all cases the hand of rotation is as seen looking on the propeller or the engine flywheel from aft of the boat.

The output shaft is supported by a roller bearing at the forward end and a ball race at the output end, and carries the appropriate size output gear, and the output flange.

Sealing arrangements for the PRM100 and PRM140 include a 54 millimetre bore seal, with 9½ millimetre retainers on the output shaft, and a 25 millimetre bore seal on the input shaft. Seals of similar type are fitted on the PRM175, PRM250 and PRM265, the bore of the output shaft seal bearing being 68 millimetres with 9½ millimetre retainers and the bore of the input shaft seal being 30 millimetres. A magnetic drain plug is fitted at the front of the gearbox casing; this can be removed for connection of suitable pipe-work to the two-way tap and the hand-operated sump drain pump provided on most engines.

Oil pump

A cast iron gear-type pump externally mounted at the rear of the gear case and normally driven by the layshaft supplies oil at high pressure for actuation of the clutch assemblies. For continuous lubrication of the clutches and for circulation through the oil cooler, the pressure is reduced.

Valve block

The valve block, located on top of the casing, contains the main control valve, a high-pressure relief valve, and two pressure differential valves, all of which are accessible cartridge-type units. The high pressure relief valve is integral with the control valve, which controls the operation of the clutch assemblies. One of the pressure differential valves protects the oil cooler and the other diverts lubricating oil, surplus to clutch requirements, back to the sump.

The turret, or drum, section of the valve block houses the control valve and is fitted with a spring-loaded neutral detent. This detent also ensures positive selection of either the forward or reverse operating position, and an added feature is the provision of an end stop to safeguard against possible overshoot of the operating lever. The lever has two-cable entry positions, one at each end.

A cartridge-type 15 micron by-pass filter, mounted on the valve block, provides continuous filtration of the circulating oil.

INSTALLATION

The design of the gearbox is such that it is possible to mount the unit in any one of four basic positions, right-hand vertical, right-hand horizontal, left-hand vertical and left-hand horizontal.

Right-hand vertical (VR) : This is the standard position, the gearbox being tilted to port, so that the input shaft is vertical to the output shaft.

Right-hand horizontal (HR): The gearbox is tilted to starboard, so that the input shaft is horizontal to the output shaft. The standard breather is blanked off, an alternative air filter fitted, and the dipstick is positioned on the port side of the gearcase.

Left-hand vertical (VL): The input shaft and layshaft assemblies are transposed and the gearbox tilted to starboard, so that the input and output shafts are again in a vertical plane. The oil pump is turned through 180 degrees, the standard air filter is used and the dipstick is positioned on top of the gearcase on the port side.

Left-hand horizontal (HL): The input shaft and layshaft assemblies are transposed with respect to the standard position, the oil pump turned through 180 degrees, and the gearbox tilted to port so that the input and output shafts are in a horizontal plane. A special oil intake pipe is included, the standard breather is blanked off, and an alternative air filter is fitted. The dipstick is positioned on the starboard side of the gearcase.

Before installing the gearbox, check that it is correct for the mounting attitude required, and then proceed as follows:

PRM100, PRM140(S), PRM175, PRM250 AND PRM265(S)

1. Mount the damping, or drive, plate to the engine flywheel, using an alignment mandrel (if available) and secure. If a mandrel is not available, tighten the drive plate bolts just sufficiently to prevent free movement, assemble the gearbox to the drive plate and rotate the engine two or three revolutions by hand to line up the plate. Tighten two or three opposite bolts through the flywheel housing inspection cover.
2. Remove the gearbox and fully tighten all the drive plate bolts.
3. Mount the adaptor plate to the gearbox facing, concentric with the input shaft, ensuring the alignment is correct, for the position required. Adaptors to suit SAE 2, 3, and 5 housings can be provided, as well as certain special adaptors to suit specific engines.
4. Offer up the gearbox and adaptor assembly to the engine drive plate and flywheel housing and enter the input shaft spline in the opposite spline on the drive plate. It may be necessary to rock the gearbox slightly to ensure the shaft enters. Press the gearbox/adaptor assembly fully into position.
5. Bolt the adaptor to the flywheel housing.
6. Mount an approved type oil cooler to the adaptor, remove the two "Redcap" plugs from the ends of the valve block and connect the cooler inlet and outlet oil connections to the block. Connect the appropriate water hoses, or pipes, to the cooler water connections, one at each end of the cooler.
7. If remote control of the gearbox is required, remove the operating lever from the valve block and connect up the control equipment in accordance with the manufacturer's instructions. For gearboxes not fitted with an external stop (serial numbers up to 1180), the movement of the operating lever should be arranged so that the control drum does not come up hard against the internal stop, or otherwise internal damage may eventually occur.
8. Connect the output flange via a suitable coupling to the propeller shaft.
9. If the oil pressure is to be indicated, an oil pressure gauge should be connected to the valve block in the position shown on the Installation Details drawing, (See pages 8 and 9).
10. Check the gearbox for oil, and if necessary, fill with one of the recommended lubricants to the 'High' mark on the dipstick.
11. Set the control lever to the neutral position and run the engine to allow the oil to circulate through the oil cooler. Stop the engine and again check the level when the oil has settled.

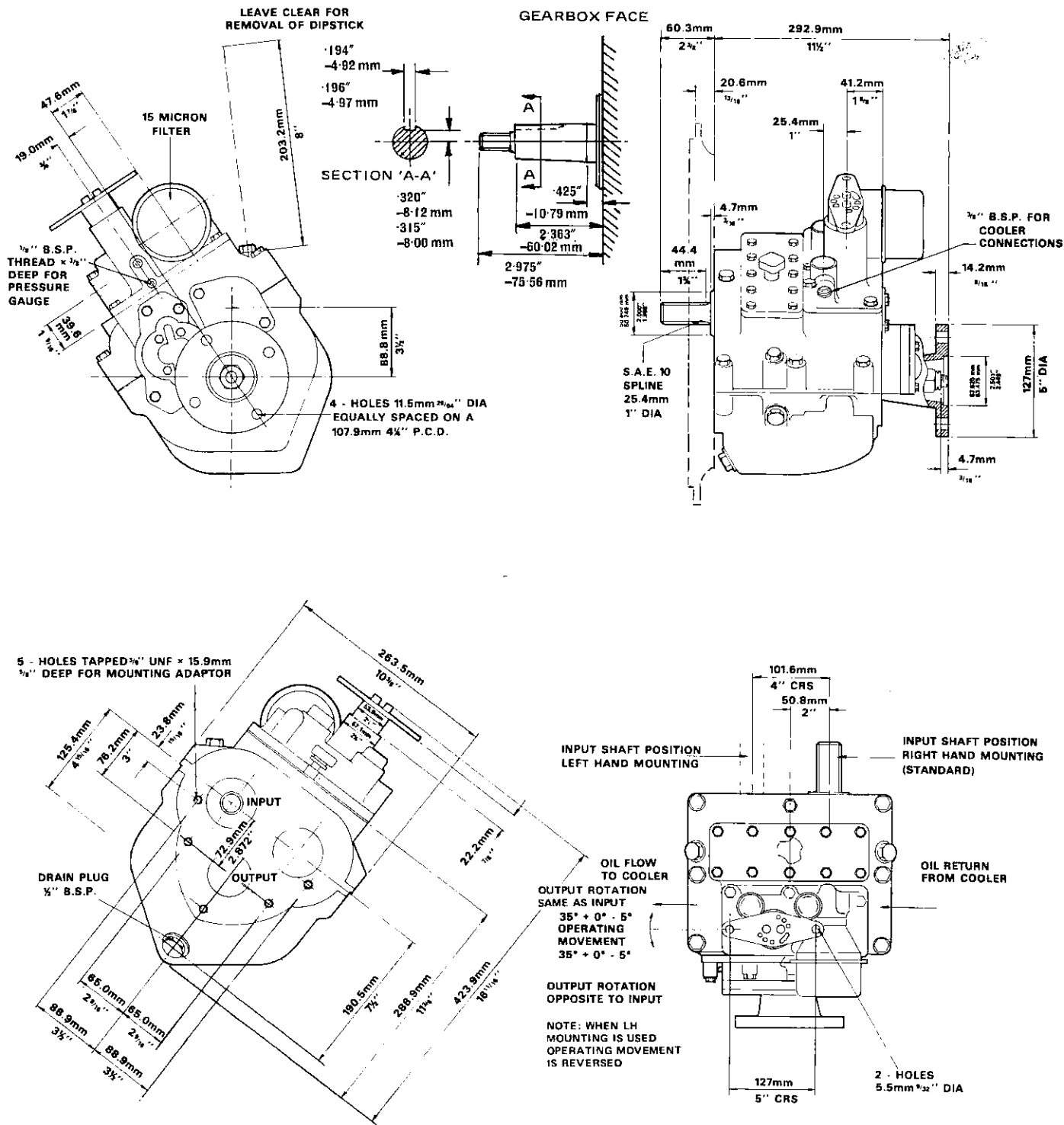

Fig. 2 - PRM100 and 140 (S) & (T) Installation details.

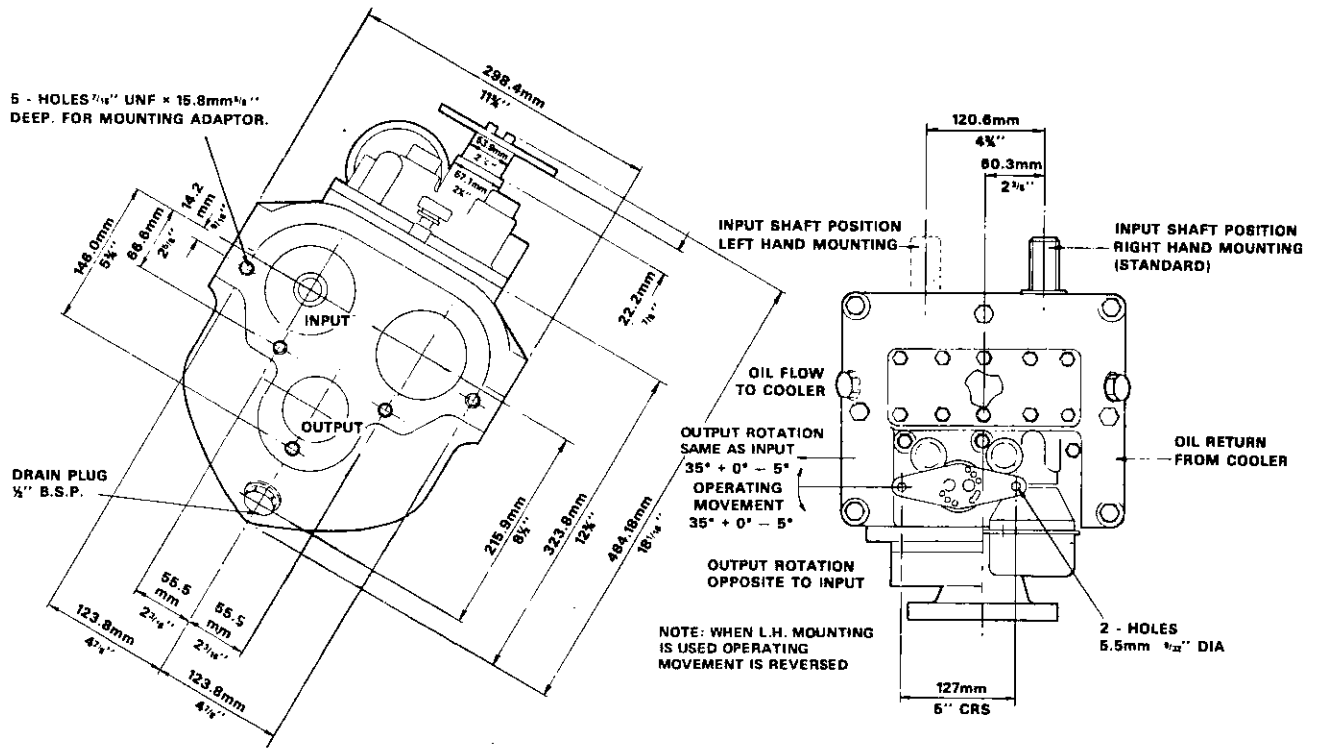
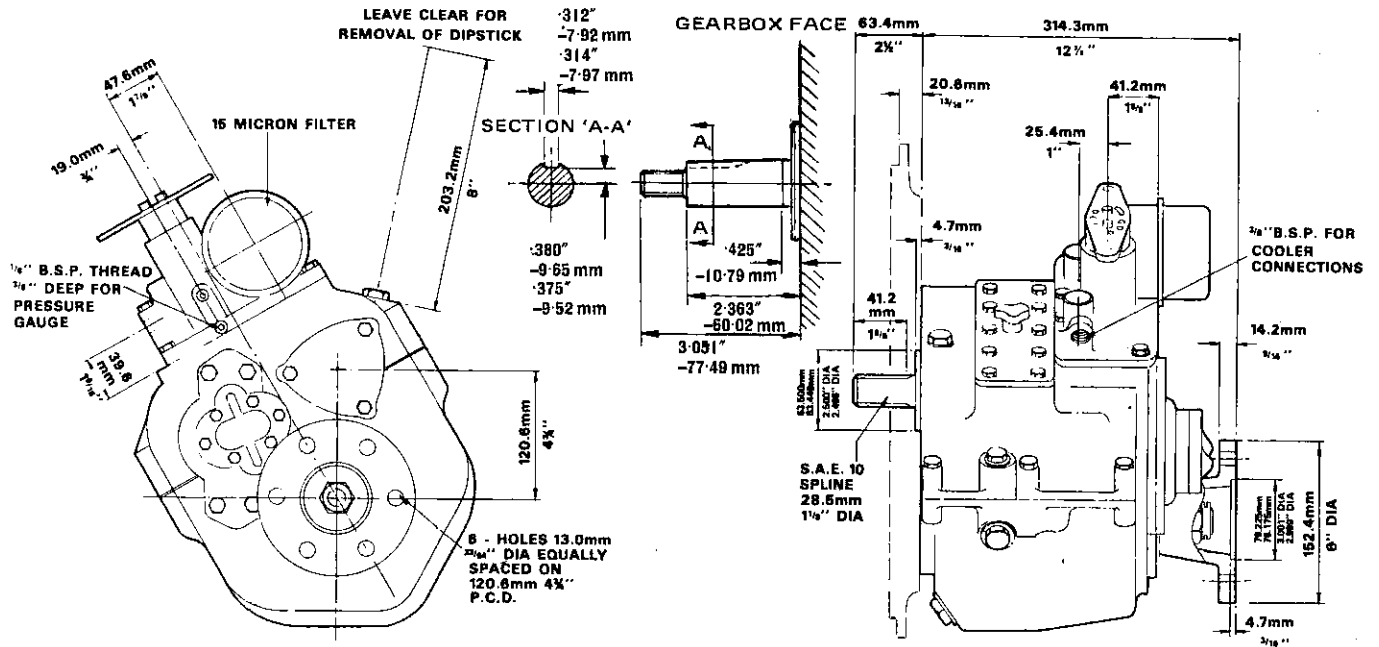

Fig. 3 - PRM175, 250 and 265 (S) & (T) Installation details

PRM140(T) AND PRM265(T)

1. Mount the driver half of the input coupling to the engine flywheel by using the outside diameter (8.5 in) (215.9 mm) for location.
2. Fit the flexible inner member into the centre of the driver half coupling.
3. Bolt the appropriate adaptor flange or flywheel housing to the mounting face of the gearbox.
4. Fit the driven half coupling to the tapered input shaft of the gearbox using the key, washer and lock nut supplied.
5. Offer up the gearbox and adaptor flange or flywheel housing to the engine backend ensuring that the driver and driven halves of the input coupling are correctly located.
6. Fit and tighten the bolts securing the adaptor flange or flywheel housing to the engine backend.
7. Mount an approved type oil cooler to the adaptor, remove the two "Redcap" plugs from the ends of the valve block and connect the cooler inlet and outlet oil connections to the block. Connect the appropriate water hoses, or pipes, to the cooler water connections, one at each end of the cooler.
8. If remote control of the gearbox is required, remove the operating lever from the valve block and connect up the control equipment in accordance with the manufacturer's instructions. For gearboxes not fitted with an external stop (serial numbers up to 1180), the movement of the operating lever should be arranged so that the control drum does not come up hard against the internal stop, or otherwise internal damage may eventually occur.
9. Connect the output flange via a suitable coupling to the propeller shaft.
10. If the oil pressure is to be indicated, an oil pressure gauge should be connected to the valve block in the position shown on the Installation Details drawing (see pages 8 and 9).
11. Check the gearbox for oil, and if necessary, fill with one of the recommended lubricants to the 'High' mark on the dipstick.
12. Set the control lever to the neutral position and run the engine to allow the oil to circulate through the oil cooler. Stop the engine and again check the level when the oil has settled.

Changing the mounting position

The gearbox is supplied equipped for mounting in the position required, but if at any time it is necessary to change the mounting position, an alternative air filter, dipstick assembly and oil intake pipe, as well as a breather blanking plug, may be required, depending on the positional change (see Fig. 4).

Frequently; when changing from a right-hand mounting position to a left-hand position, the gearbox will be required to operate with a left-hand rotating propeller. In this event it will be necessary to transfer the emergency drive splined ring and the splined clutch end cover from the input shaft to the layshaft if the 'get you home' device is to function as intended.

To change from VR to VL or VL to VR

1. Remove the gearbox from the engine and remove all ancillary equipment i.e. oil cooler pipes, adaptor flange and control head.
2. Stand the gearbox in the upright position and remove the dipstick and the flanged plug from the opposite side of the gearbox top half case.
3. Remove the valve block assembly and the top cover containing the "get-you-home" device fork.
4. Remove the oil pump assembly and end cover. Note the position of the oil pump assembly.
5. Remove the top half of the gearcase.
6. Lift out the input shaft and layshaft assemblies and transpose. If the gearbox is to operate with an opposite hand of propeller to that which was used originally remove both drive pinions and transfer the splined ring and endcover from one shaft assembly to the other.
7. Replace the top half of the gearcase ensuring that the feeders are aligned with the corresponding holes in the case, and that the 'O' rings have not been damaged.
8. Replace the valve block assembly and top cover ensuring that the emergency ring is located in the normal running position i.e. in front of the retaining fork.

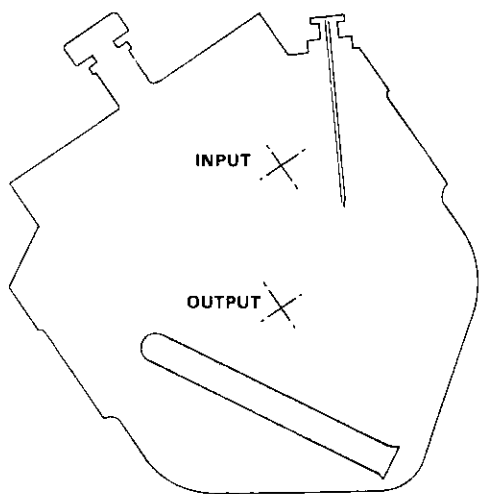

RIGHT HAND MOUNTING – VERTICAL (VR)

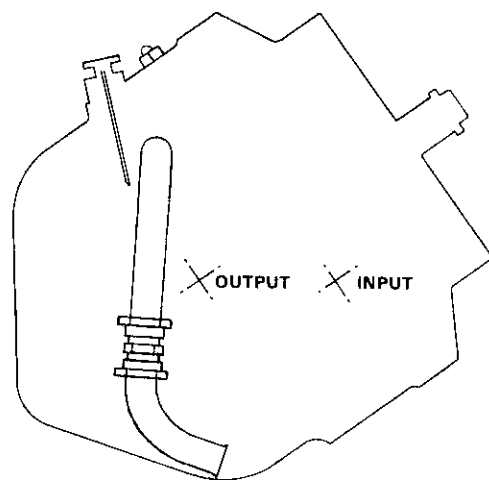

RIGHT HAND MOUNTING – HORIZONTAL (HR)

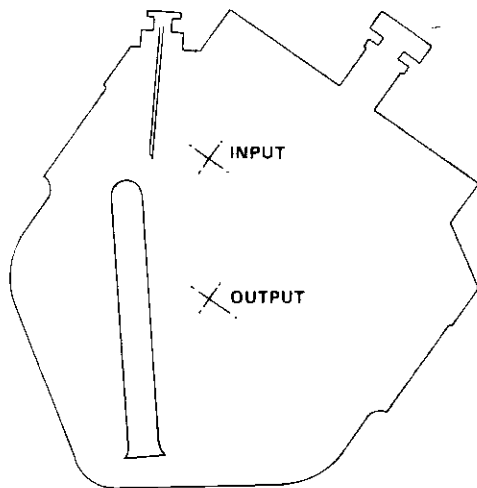

LEFT HAND MOUNTING – VERTICAL (VL)

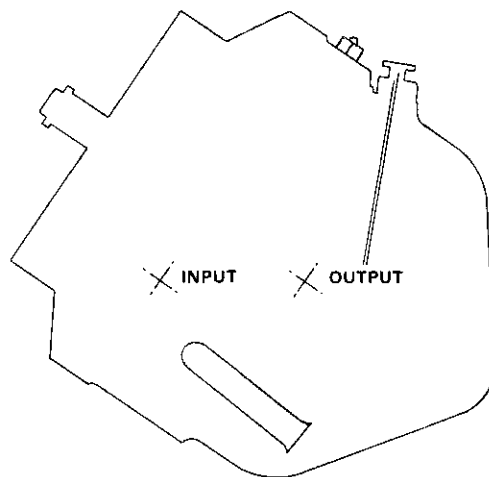

LEFT HAND MOUNTING – HORIZONTAL (HL)

Fig. 4 Basic Installation Positions

PRM100 AND 140 (S) & (T)

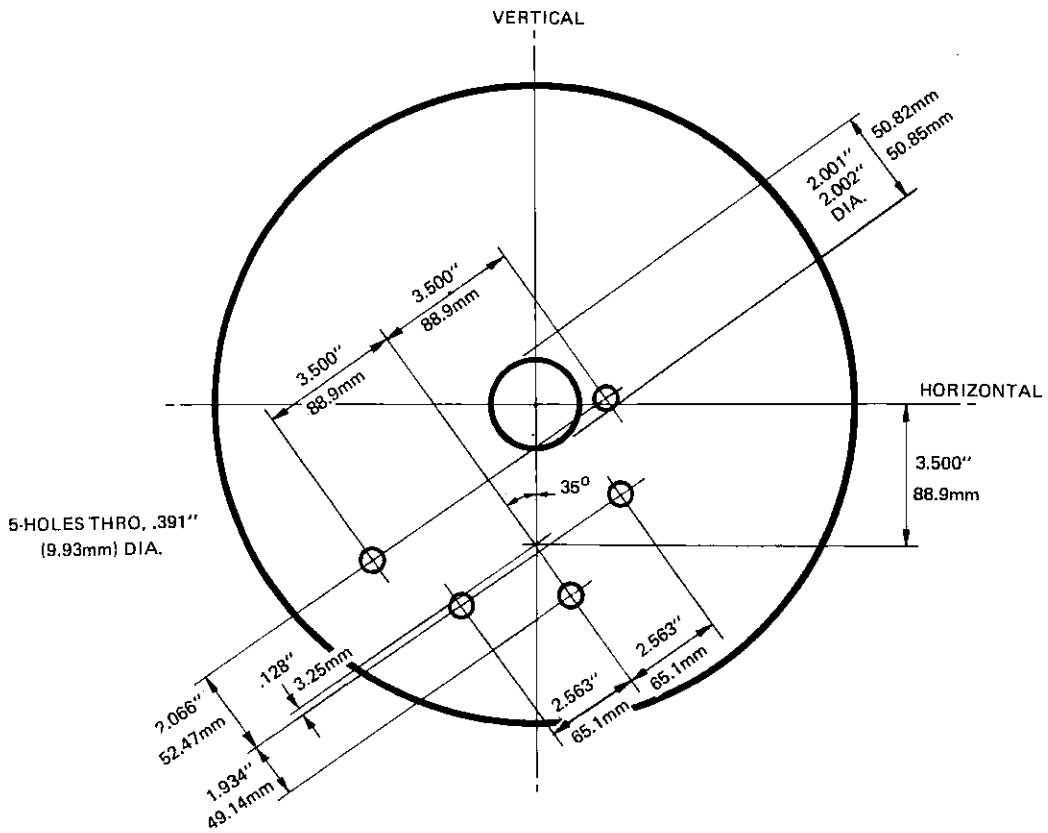

PRM175, 250 AND 265 (S) & (T)

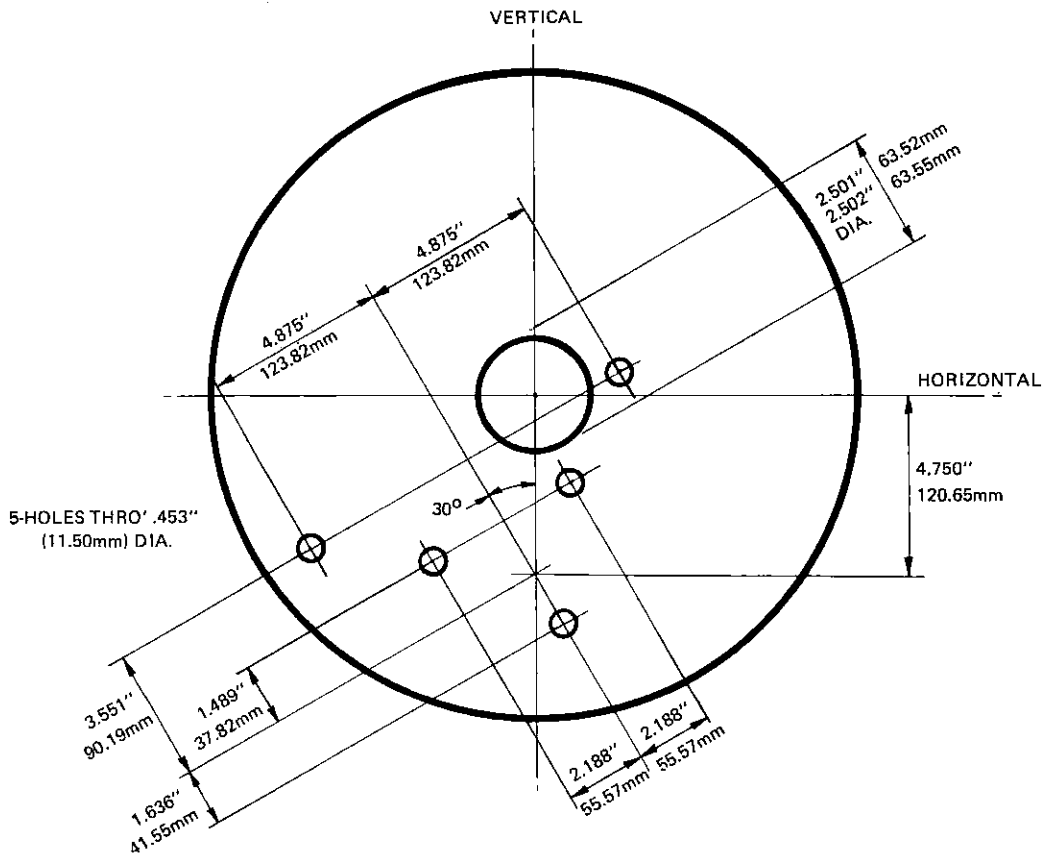

Fig. 5 Adaptor Flange drilling details (Gearbox - adaptor)

9. Turn the oil pump through 180° from its original position and refit to the gearcase. Refit the end cover.
10. Transpose the dipstick and flanged plug so that when the gearbox is fitted in its new mounting position the dipstick is uppermost. (See Fig. 4 - Basic mounting positions).
11. Re-drill the existing adaptor plate or fit the new adaptor flange utilising the five bolts.
12. Refit all the ancillary equipment and re-assemble the unit to the engine flywheel housing.

“ If gearboxes are required for mounting the horizontal right to horizontal left positions this should be specified at the time of order. If vertically mounted gearboxes must be changed to horizontal mounting, specific instructions should be sought from the factory since additional internal components may be required”.

RECOMMENDED LUBRICANTS

Climatic Conditions	Esso	Mobil	Shell	B.P.	Duckhams	Castrol
Above 90°F (32°C)	Esso Extra 20W/30 or Essofleet H.D.30	Delvac Oil 930	Rotella 30	Energol D.D.30	Duckhams Multigrade Q20/50	Castrol C.R.30
90°F (32°C) down to 10°F (-12°C)	Esso Extra 20W/30 or Essofleet H.D. 20	Delvac Oil 920	Rotella 20/20W	Energol D.D.20W	Duckhams Multigrade Q20/50	Castrol C.R.20
10°F (-12°C) down to 0°F (-18°C)	Esso 10W or Essofleet H.D.10W	Delvac Oil 910	Rotella 10W	Energol D.D.10W	Duckhams Q5500	Castrol C.R.10

OPERATION

With the control lever in the mid-point of travel or neutral position, and the engine running, the splined input drive shaft and clutch gear revolve at engine speed. The clutch gear, in continuous mesh with the clutch gear on the layshaft, drives the layshaft in the opposite direction, but the drive pinions do not rotate.

On moving the control lever to the forward drive position, hydraulic action causes the clutch on the input drive shaft to engage and apply engine drive to the forward drive pinion. The pinion turns the gear on the output shaft and the propeller and propeller shaft rotate in the direction which corresponds with ahead movement of the vessel. Likewise when the control lever is operated to the reverse position the clutch on the layshaft engages and engine drive is applied to the reverse pinion. The pinion turns the gear on the output shaft in the opposite direction and the propeller shaft and propeller rotate in the direction corresponding to astern movement of the vessel.

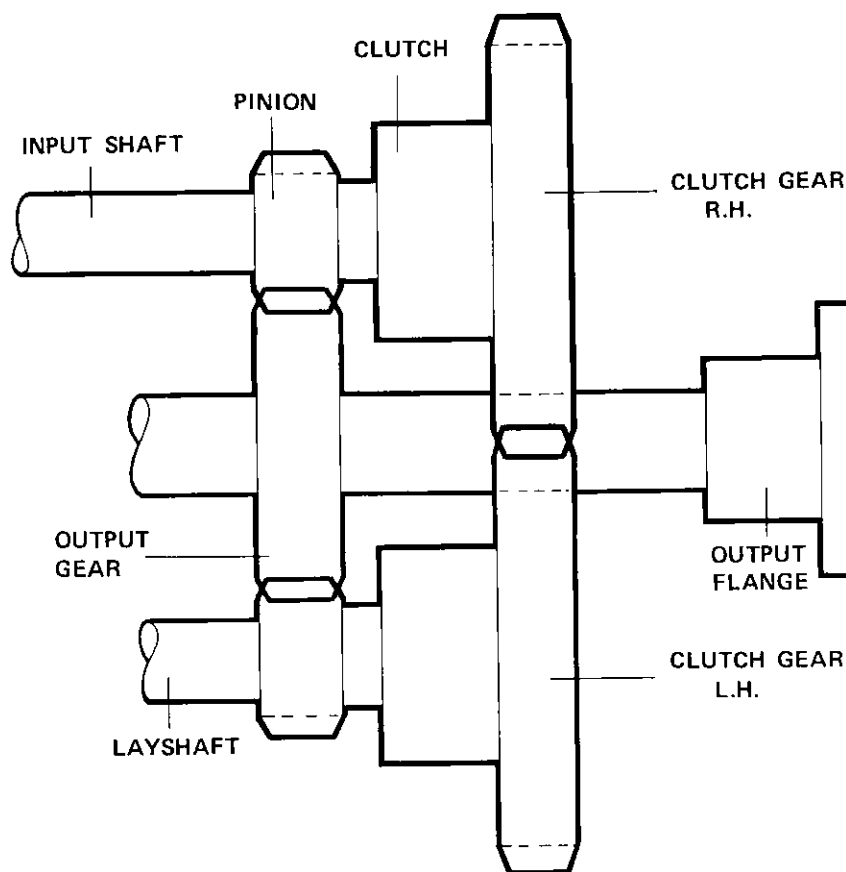

Fig. 6 Internal layout diagram – standard gearbox

Hydraulic action

The oil pump draws oil from the gearbox sump through the internal lubricating pipe and delivers it to the valve control block. A high pressure relief valve in the control valve maintains pressure, and oil flows through an outlet in the control valve, on through a channel, or passage in the control block, and a feeder on either the drive shaft or layshaft, depending on the lever position, to the appropriate piston.

Operation of the piston then actuates the corresponding clutch assembly.

Excess oil passes the high pressure relief valve for lubrication purposes.

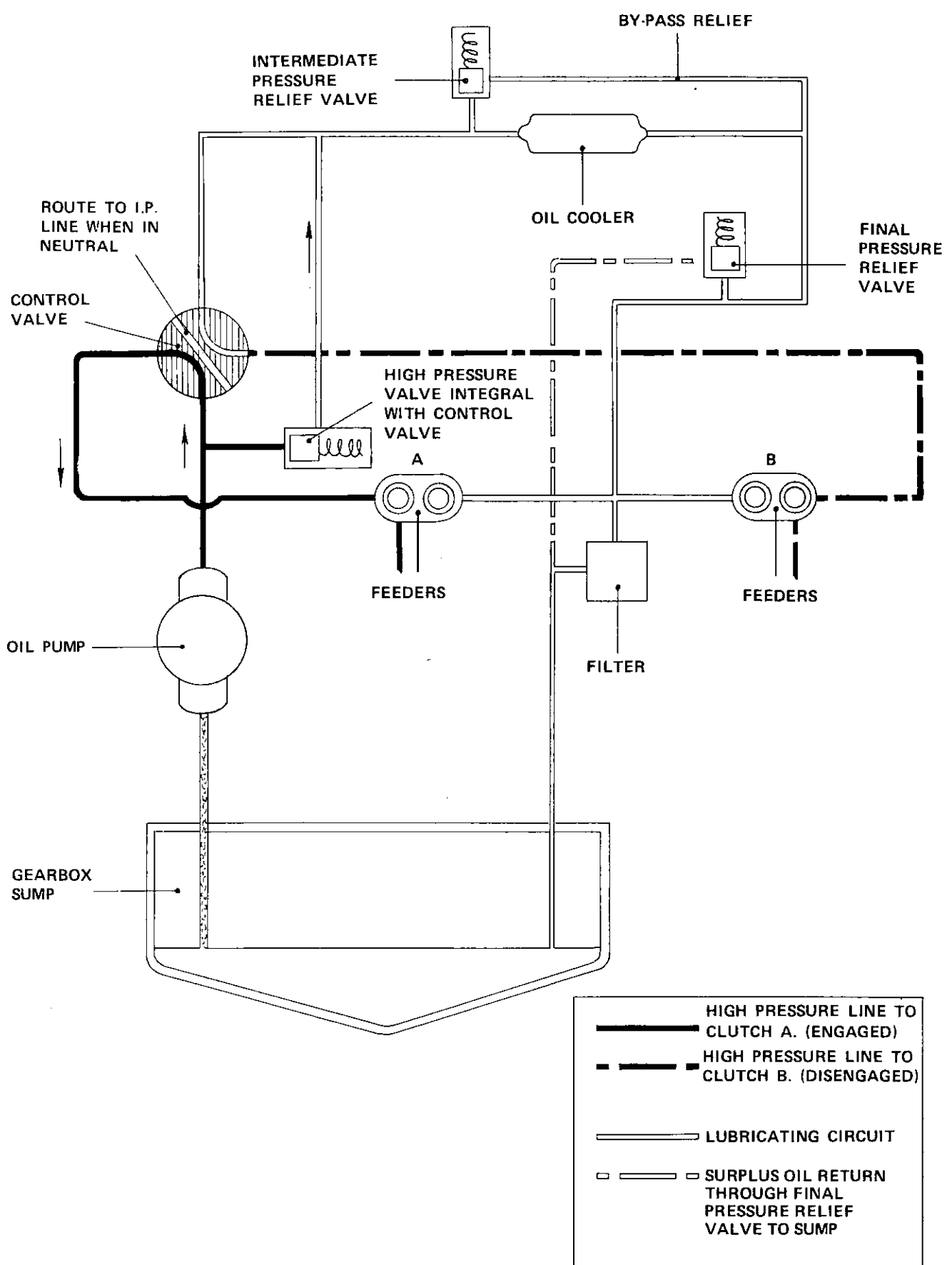

—————	HIGH PRESSURE LINE TO CLUTCH A. (ENGAGED)
- - - - -	HIGH PRESSURE LINE TO CLUTCH B. (DISENGAGED)
—————	LUBRICATING CIRCUIT
- - - - -	SURPLUS OIL RETURN THROUGH FINAL PRESSURE RELIEF VALVE TO SUMP

Fig. 7 Oil Flow Diagram

Lubrication

It will be seen from the oil flow diagram (Fig. 7) that oil for lubrication purposes is also delivered via the internal lubricating pipe to the control block. With the gearbox in neutral a subsidiary outlet in the control valve allows oil at reduced pressure to flow through the control valve and valve block to an external oil cooler which is protected by a differential pressure relief valve, or intermediate pressure relief valve. On returning from the cooler the oil is directed through channels in the valve block to the feeders and thence through the layshaft and drive shaft to lubricate the clutch assemblies.

With the gearbox in forward or reverse gear the oil is diverted via the high pressure relief valve in the control valve to the oil cooler and clutch assemblies.

Oil, surplus to clutch requirements, is pressurised by a second differential pressure relief valve, or final pressure relief valve, which opens and diverts the surplus oil back to the sump.

Emergency operation

A device is included in the gearbox which will permit the transmission to operate in the forward gear should hydraulic or clutch failure occur.

To lock the transmission in ahead drive simply remove the top cover, including fork, then replace the cover with fork in front of the emergency splined ring and move the cover back to align with the bolt holes.

The splined ring is thus removed to the engaged position.

Replace the cover bolts and secure.

NOTE: As this is purely an emergency 'get-you-home' device the engine should be set to only one third of full throttle to avoid the possibility of further damage due to lubrication difficulties. Permanent repairs should be undertaken as soon as possible after breakdown of the transmission and in all probability it will be necessary to strip the clutch assembly to dis-engage the mechanism, as described under 'General Maintenance'.

WARNING: Under no circumstances must the access to the 'get-you-home' device be used to fill or top up the gearbox with oil.

ROUTINE MAINTENANCE

Routine maintenance is confined to regular oil level checks and oil changes, at intervals which should correspond with the intervals for engine oil changes. The by-pass filter should not normally require replacement, but if the gearbox oil has suffered severe contamination by water, or major mechanical damage, replacement will be necessary.

Initial servicing - after 25 running hours

If fitted, set the two-way cock on the hand operated pump, mounted at the rear of the engine, to the rear position and operate the pump to drain the gearbox. If no such pump is fitted, simply remove the drain plug from the front of the gearbox and drain the oil into a suitable receptacle. Refill with one of the recommended lubricants to the high level mark on the dipstick and allow the oil to circulate. Stop the engine and again check the oil level when the oil has settled.

GENERAL MAINTENANCE

Maintenance as applied to components or assemblies on the input drive shaft or layshaft is simplified by the ease with which the shafts can be removed from the box without having to remove the complete unit from the installation.

This can be further simplified by fitting complete replacement shaft assemblies, and where skilled service personnel, or workshop facilities, or both, are not readily available, it will be found advantageous to adopt this procedure.

Output shaft maintenance, with the exception of the oil seal, will necessitate removal of the unit from the installation.

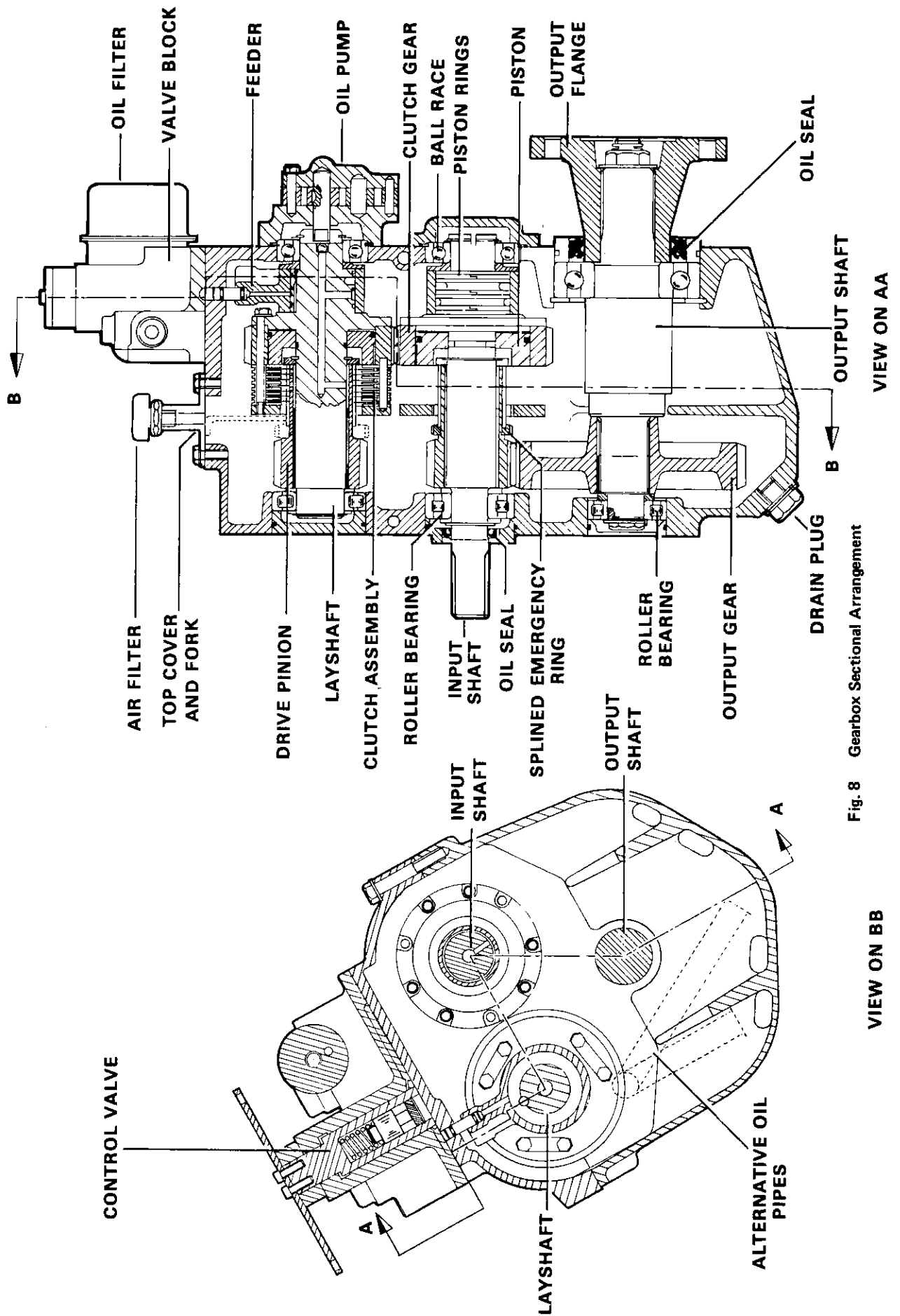

Fig. 8 Gearbox Sectional Arrangement

A sectional arrangement of the gearbox is shown in Fig. 8, a dismantled input shaft assembly is illustrated in Fig. 13, a layshaft assembly in Fig. 14 and the output shaft and the two halves of the gear casing in Fig. 15.

REMOVING THE INPUT SHAFT AND LAYSHAFT ASSEMBLIES

PRM100, PRM140S, PRM175, PRM250 AND PRM265S

1. Drain the gearbox oil into a suitable container.
2. Remove the four bolts securing the oil pump to the casing and remove the pump.
3. Remove the two bolts (PRM100 and PRM140S) or three bolts (PRM175, PRM250 and PRM265S) securing the drive shaft end plate or layshaft end plate (left-hand mounting) and remove the plate.
4. Disconnect the oil cooler pipes and the cable or cables from the control lever or control equipment.
5. Unscrew and withdraw the seven bolts and the one nut on the valve block which secure the top half of the casing. Lift off the casing complete with valve block assembly and top cover.
6. Slacken the flywheel damping plate securing bolts to allow slight movement of the plate when withdrawing the input shaft spline. On units incorporating 3:1 reduction it is recommended that all bolts except one are removed from the damping plate and the plate pivoted on this one bolt to enable the shaft to be lifted clear of the gear on the output shaft.
7. Raise the shaft, and if necessary gyrate a little to withdraw the spline from the opposite spline on the damping plate.
8. Once the spline is clear, lift the complete shaft assembly from the casing. Lift and remove the layshaft assembly and the front end cover from the casing.

PRM140(T) AND PRM265(T)

1. Drain the gearbox oil into a suitable container.
2. Disconnect the oil cooler pipes and the cable or cables from the control lever or control equipment.
3. Remove the gearbox and adaptor flange from engine backend.
4. Remove the lock nut and washer from the end of the input shaft and draw the driven half coupling hub from the tapered shaft by means of a hub-extractor.
5. Remove the four bolts securing the oil pump to the casing and remove the pump.
6. Remove the two bolts (PRM140) or three bolts (PRM265) securing the drive shaft end plate or layshaft end plate (left-hand mounting) and remove the plate.
7. Unscrew and withdraw the seven bolts and the one nut on the valve block which secure the top half of the casing. Lift off the casing complete with valve block assembly and top cover.
8. Lift the complete shaft assembly from the casing. Lift and remove the layshaft assembly and the front end cover from the casing.

INPUT CLUTCH SHAFT

Oil seal

In the event of an oil leak due to a damaged seal, remove the input end housing from the shaft, and with the aid of a hard wood drift and hammer force the seal from the housing.

Fit a new seal Part No. MT165 (PRM100 and PRM140) or MT251 (PRM175, PRM250 and PRM265) in the housing and replace the housing.

Drive end bearing

To renew a damaged or worn bearing proceed as follows:-

1. Support the shaft in a vice and then remove the input housing and seal assembly.
2. Using circlip pliers remove the bearing circlip and spacer located behind.
3. Withdraw the clutch pinion, spacer and bearing using pulley extractors with the jaws of the extractors located behind the pinion.
4. Refit the clutch pinion to the shaft first ensuring that the splined emergency drive ring is in position on the pinion (right-hand mounted box).
5. Replace the pinion spacer, locate a new roller bearing Part No. T7023 (PRM100 and PRM140) or MT412 (PRM175 and PRM250) or 0533026 (PRM265) on the shaft and gently drive, with a hard wood drift hammer, or press, the assembly into position. If the outer cage separates from the inner be careful not to damage the rollers.
6. Replace the bearing spacer and refit the circlip and end housing, first ensuring the seal and 'O' ring are intact.

Clutch Assembly

Clutch plates which are discoloured by overheating, or worn down to the extent of having lost their pattern of 'criss cross' grooves, will tend to slip. If either of these conditions arise the complete drive plate assembly will need to be replaced in the following way:-

1. Remove the drive pinion and bearing as described, unlock the six clutch securing bolts and remove the bolts and locking strips, taking care not to lose any of the locating ferrules.
2. Withdraw the complete clutch from the shaft and observe the positions of the pull-off springs and pins.
3. Position the drive pinion, on gear end face, on packing which will allow the shaft to pass through the pinion on assembly.
4. Load the clutch end cover and plate on to the pinion, first ensuring the splined ring is in position. If the pins have separated from the clutch end cover re-locate them.
5. Load a replacement clutch pack on to the end plate ensuring the opposite end plate is uppermost.
6. Replace the clutch springs on the retaining pins.
7. If the piston has separated from the clutch gear, replace, and re-position both components on the shaft.
8. Load the shaft through the pinion and re-locate the retaining pins in the clutch gear.
9. Replace the securing bolts and locating strips, and lightly tighten. Then, one at a time, remove each bolt, locate the associated ferrule, and replace the bolt. When all the bolts are replaced tighten with a torque spanner set to a torque of 9 lbf.ft (1.24 kgm) and close the locking strip tags.
10. Place the thick spacer and bearing on to the shaft and gently drive the bearing into position.
11. Refit the second spacer, circlip and input end housing.

An alternative method involves the use of a hand press to assist in refitting the clutch, clutch pinion and bearing. When this method is adopted the complete clutch is loaded on to the pinion and the pinion and bearing are located on the shaft for pressing into position. Before using the press, great care should be taken to ensure that the whole shaft assembly is correctly aligned otherwise damage will result.

Clutch gear

To fit a new clutch gear, Part No. MT333 (PRM100 and PRM140) or MT397 (PRM175, PRM250 and PRM265), remove the clutch as described and then extract the piston retaining spacer and circlip, to allow the piston and clutch gear to be removed from the shaft.

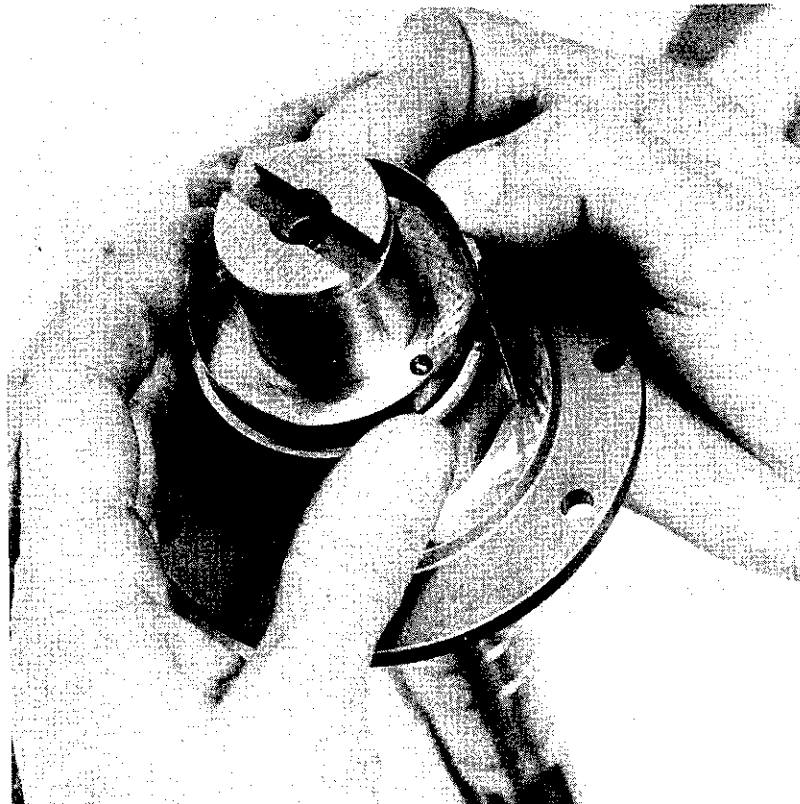

Fig. 9 Piston rings – fitting procedure

Separate the gear from the piston, ensure the inner and outer piston ring step joints are intact, then fit a new gear around the piston.

Refit the piston to the shaft. Replace the circlip and spacer and then re-assemble the clutch, drive pinion and bearing.

NOTE: To ensure quiet operation it is advisable to renew both clutch gears simultaneously.

Drive pinion

To renew a drive pinion, remove the drive end bearing and pinion with pulley extractors as described. If worn, the emergency drive spline ring should also be renewed and, as with the clutch gears, it is advisable to renew both pinions simultaneously.

Ensure the correct ratio pinion is selected by reference to the parts list at the end of this section. If a different ratio to the one being used is required both pinions will have to be changed; also the output gear.

Non-drive end bearing

Remove the bearing circlip and spacer, and using pulley extractors withdraw the bearing from the shaft.

Fit a new ball race, Part No. MT160 (PRM100 and PRM140) or MT404 (PRM175, PRM250 and PRM265), to the shaft and refit the spacer and circlip.

Piston rings and Feeder

Excessive wear or damage may necessitate renewal of the piston rings and feeder, and in this event the following procedure should be adopted.

1. Remove the non-drive end bearing and withdraw the spacer and the feeder.
2. Use a special piston ring extractor or a piece of thin steel such as a smoothly ground hacksaw blade to remove the rings from the shaft.
3. Raise one end of the top ring out of the groove and insert the steel strip between the ring and the shaft. Rotate the strip around the shaft, applying slight forward pressure to the raised portion of the ring until it rests on the land above the groove. It can then be eased off the shaft. Do likewise with the other two rings.
4. Remove the new rings, Part No. CP1192 (PRM100 and PRM140) or MT292 (PRM175, PRM250 and PRM265), from the packing and clean off any grease or inhibitor.
5. If available, fit a ring loading tool around the shaft, load the rings on the tool and locate in their approximate position. Gently withdraw the tool and allow the rings to locate in their grooves.
6. Where a loading tool is not available use a thin metal strip, long enough to lay along the shaft above the grooves. Expand each ring just sufficient to allow them to be placed in approximate position over the strip. Gently remove the strip and locate the rings in their respective grooves, (See Fig.9).
7. Compress each ring in turn and carefully fit a new feeder, Part No. MT315 (PRM100 and PRM140), or MT380 (PRM175, PRM250 and PRM265), and spacer.

LAYSHAFT

Drive end bearing

The bearing fitted to the PRM100 and PRM140 layshaft is identical with the bearing on the input shaft and the same applies to the PRM175, PRM250 and PRM265; renewal procedure is similar.

1. Remove the bearing circlip and spacer and withdraw the bearing.
2. Fit a new bearing to the shaft and refit the spacer and circlip.
3. Replace the end cover, first ensuring the 'O' ring is intact.

Clutch Assembly - Drive pinion and clutch gear

The procedures for renewing the clutch assembly, clutch gear and drive pinions are the same as those described for the input shaft.

Non-drive end bearing

As with the drive end bearings, the non-drive end bearings are identical with their counterparts on the input shaft and if damaged or worn should be renewed in the same way.

Piston rings and Feeder

The same number and same size rings and feeder are fitted on the layshaft, as are fitted on the input shaft. The same renewal procedure therefore applies.

REPLACING THE INPUT SHAFT AND LAYSHAFT ASSEMBLIES

PRM100, PRM140S, PRM175, PRM250 AND PRM265S

1. Locate the input shaft assembly in the casing and engage the spline with the spline on the engine damping plate. Tighten the damping plate bolts.
2. Locate the layshaft in the casing and ensure the end cover is positioned.
3. Fit the top half of the casing and secure.
4. Reconnect the oil cooler pipes.
5. Refit the oil pump and renew the 'O' rings if the existing ones are damaged. Replace the input shaft end plate.
6. Refill the box with one of the recommended lubricants, and check the oil level.
7. Reconnect the control cable, or cables, to the control equipment or control lever.
8. Run the engine, shut down and again check the oil level.

PRM140(T) AND PRM265(T)

1. Locate the input shaft in the casing. Refit the layshaft assembly and ensure the end cover is positioned correctly.
2. Refit the valve block and secure the top casing.
4. Locate the drive shaft end plate or layshaft end plate (left-hand mounting) and secure.
4. Refit the oil pump and replace damaged 'O' rings.
5. Replace the driven half coupling hub on the tapered shaft, secure with locknut and washer.
6. Remount the gearbox and adaptor flange on to the engine.
7. Reconnect the oil cooler pipes and cable/s to the control lever or control equipment.
8. Refill with one of the recommended lubricants and check oil level.
9. Run the engine, shut down and re-check the oil level.

OUTPUT SHAFT

Removal of the output shaft will necessitate removing the gearbox from the installation in the following way:-

1. Drain the gearbox oil into a suitable container. Support the unit to take the weight off the drive shaft and output shaft, remove the output flange coupling bolts and disconnect the propeller shaft coupling.
2. Disconnect the cable from the control lever.
3. Obtain access to the damping plate through the flywheel housing or inspection cover on the adaptor plate; slacken the engine damping plate securing bolts and then remove the engine/adaptor plate mounting bolts.
4. Withdraw the input shaft spline from the damping plate spline and remove the unit from the installation.
5. Remove the oil pump, the input shaft end cover and then the top half of the casing.
6. Remove the input shaft and layshaft assemblies.
7. Remove the output shaft end housing securing bolts.
8. Release the rear bearing circlip; at this stage it will not be possible to remove the circlip from the shaft.
9. Drive the shaft forward to displace the end cover.
10. Unscrew the single setscrew (PRM100 and PRM140) or the two setscrews (PRM175, PRM250 and PRM265) and remove together with the tab washer, PRM100 and PRM140 only, or shakeproof washers (PRM175, PRM250 and PRM265) and bearing retaining washer from the front of the shaft.
11. Drive the shaft backwards; this will allow the front bearing and output gear (held by web in gearcase) to be removed from the shaft.
12. Withdraw the shaft with rear bearing oil seal, output end housing and output flange from the rear of the case.
13. Before re-assembling the shaft in the casing, ensure the oil seals and 'O' rings are not damaged or worn, and follow the 'Front bearing and output gear' instructions when fitting the front bearing and output gear to the shaft.
14. Re-assemble the gearbox in the reverse order to that described above.

Front bearing and Output gear

To renew a front bearing or output gear proceed as follows:-

1. Remove the bearing and output gear from the shaft with the shaft in the casing as described.
2. If the bearing is the defective component, ensure the output gear is not damaged and then place the output gear, spacer and new bearing, Part No. 0532023 (PRM100 and PRM140 or 0533021 (PRM175, PRM250 and PRM265) in position on the shaft.
3. If the output gear is the defective component, fit a new one of the same ratio as the one removed, unless different ratio drive pinions have been fitted, and ensure the bearing is sound. Where the drive pinions have been changed, ensure the output gear ratio corresponds. Refer to Parts List for Part numbers and ratios.
4. Refit the rear bearing circlip and then, with the shaft assembly carefully aligned, drive the shaft forward until the rear bearing is up to the circlip.
5. Stand, and support the casing on the output flange and, using a hard wood drift or soft metal sleeve of correct diameter, gently drive the inner race of the front bearing into position. Replace the bearing outer cage and secure with tabwasher (when fitted), washer(s) and screw or screws.

Oil seal

Providing there is sufficient space and clearance when the propeller shaft coupling is disconnected to allow the output flange to be withdrawn the oil seal may be renewed, without removing the gearbox from the installation.

1. Restrain the output flange from turning by 'barring' it with a lever locked against bolts placed in the coupling holes. Remove the flange locking nut and spacer.
2. Withdraw the flange with pulley extractors, remove the output end housing and extract the oil seal.
3. Examine the housing 'O' ring and if worn or damaged, renew.
4. Check the oil seal bearing surfaces for wear, and, if grooved, replace the output flange.
5. Fit a new seal, Part No. MT349 (PRM100 and PRM140), or MT252 (PRM175, PRM250 and PRM265) check the oil seal sleeve and refit the housing and seal to the output flange.
6. Locate the output flange on the shaft and, using a wooden drift and hammer gently drive the flange into position.
7. Replace the spacer and locknut and tighten to a torque of 250 lbf.ft (34.5 kg.m).

Rear bearing

With the output shaft removed from the casing remove the flange and end housing and withdraw the bearing with pulley extractors. Fit a new bearing, Part No. A15 (PRM100), MT711 (PRM140), MT405 (PRM175) or MT451 (PRM250 and PRM265), ensure the seal is sound and re-assemble the flange and end housing.

VALVE BLOCK

The complete valve block can be removed for inspection by simply removing the five bolts and single nut.

Low pressure relief valves

The two low pressure relief valves can be withdrawn once the valve block is removed, by extracting the spring retaining rings from the valve bores.

Control valve

To remove the control valve, remove the valve block and then using an Allen key remove the two ¼ in. UNF lever retaining cap screws. Care should be taken not to lose or misplace the detent ball bearings and springs. Renew the 'O' ring Part No. 0,01313 if damaged or defective.

High pressure relief valve

Removal of the high pressure relief valve is effected by simply withdrawing the circlip in the base of the control valve. Valve stop, valve and spring will then slide out.

SPARE PARTS ORDERING

When ordering spare parts the following should be quoted:—

- (a) Gearbox model and serial number.
- (b) Description(s) and part number(s) of the component(s) required.
- (c) Quantity required.

NOTES:

1. Individual items which form part of an assembly, or main component, are indented and may be supplied separately; if the assembly is ordered all components pertaining to that assembly are supplied. For example if the 'clutched input shaft' assembly is ordered the shaft itself and every item called up and shown on the corresponding illustration will be supplied, with the exception of the end housing and oil seal. The same applies to the layshaft.
2. Clutch plate assemblies, i.e. end plates, driven plates and driver plates are supplied in sets.

Orders and enquiries for spare parts should be addressed to:

NEWAGE ENGINEERS LIMITED
TRANSMISSIONS DIVISION
BARLOW ROAD
COVENTRY CV2 2LD
ENGLAND

Telephone (0203) 617141

Telex 31333

Cables 'SUPAGEARS' Coventry.

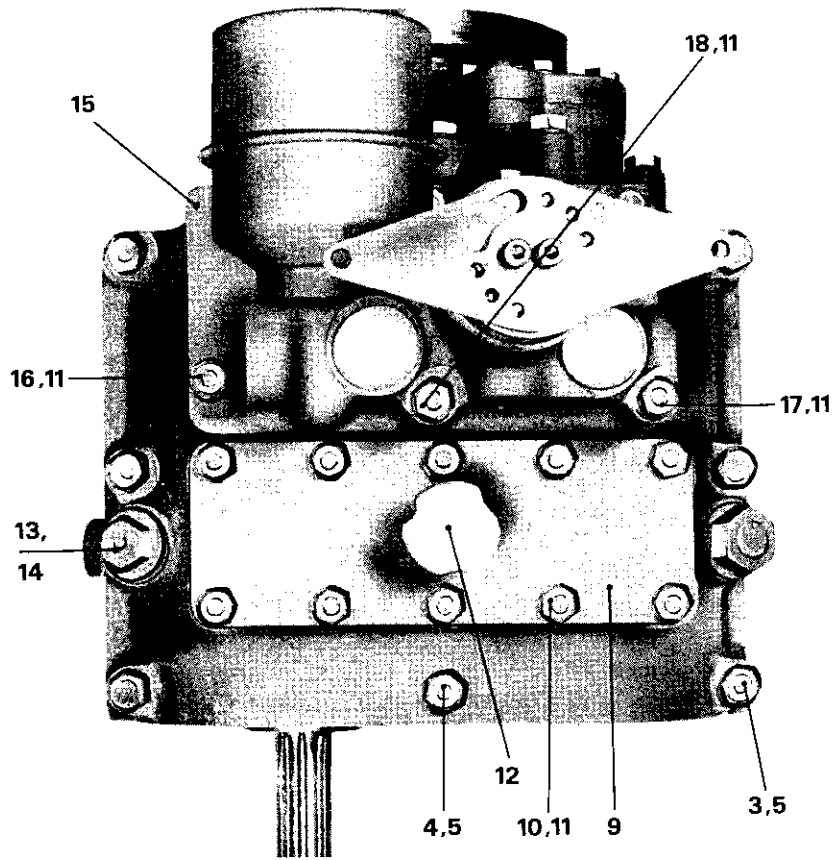

Fig. 10 Gearbox top view

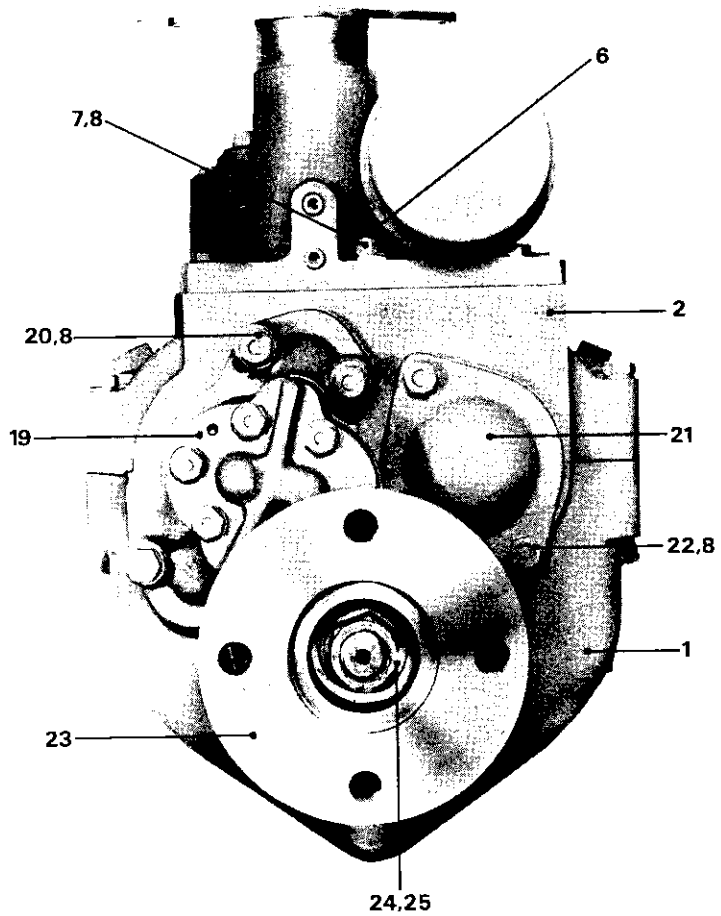

Fig. 11 Gearbox Rear view

PARTS LIST

Plate Ref.	Description	PRM100 Part No.	Qty	PRM140 Part No.	Qty	PRM175 Part No.	Qty	PRM250 Part No.	Qty	PRM265 Part No.	Qty
1	GEARCASE - Bottom	MT102	1	MT102	1	MT215	1	MT215	1	MT215	1
2	GEARCASE - Top	MT103	1	MT103	1	MT216	1	MT216	1	MT216	1
3	Bolt - gearcase	UBF113	6	UBF113	6	UBF113	6	UBF113	6	UBF113	6
4	Bolt - gearcase	UBF173	1	UBF173	1	UBF163	1	UBF163	1	UBF163	1
5	Washer - bolt	W108	8	W108	8	W108	8	W108	8	W108	8
6	Stud - gearcase	MT310	1	MT310	1	MT373	1	MT373	1	MT373	1
7	Nut - stud - 3/8" UNF	UN505	1	UN505	1	UN505	1	UN505	1	UN505	1
9	TOP COVER	MT735	1	MT735	1	MT743	1	MT743	1	MT743	1
	Plug - breather (Horizontal mounted box)										
10	Screw - cover	CP1123	1	CP1123	1	CP1123	1	CP1123	1	CP1123	1
11	Washer - sealing	USF12	10	USF12	10	USF12	10	USF12	10	USF12	10
12	FILTER - AIR (Vertical)	CP1223	10	CP1223	10	CP1223	10	CP1223	10	CP1223	10
12	FILTER - AIR (Horizontal)	CP1057	1	CP1057	1	CP1057	1	CP1057	1	CP1057	1
13	Plug - flanged	MT421	1	CP1057	1	MT421	1	MT421	1	CM2106	1
14	Washer - sealing	CP1189	3	CP1189	3	CP1189	3	CP1189	3	CP1189	3
15	VALVE BLOCK	CP1068	3	CP1068	3	CP1068	3	CP1068	3	CP1068	3
16	Screw - Valve block/gearcase	MT675	1	MT675	1	MT675	1	MT675	1	MT675	1
17	Washer - sealing	USF52	3	USF52	3	USF52	3	USF52	3	USF52	3
17	Bolt - valve block/gearcase	CP1223	3	CP1223	3	CP1223	3	CP1223	3	CP1223	3
11	Washer - sealing	UBF132	1	UBF132	1	UBF132	1	UBF132	1	UBF132	1
18	Bolt - valve block/gearcase	CP1223	1	CP1223	1	CP1223	1	CP1223	1	CP1223	1
11	Washer - sealing	UBF142	1	UBF142	1	UBF142	1	UBF142	1	UBF142	1
19	OIL PUMP ASSEMBLY (See Fig.15)	CP1223	1	CP1223	1	CP1223	1	CP1223	1	CP1223	1
20	Bolt - pump to casing	MT479	1	MT479	1	MT480	1	MT480	1	MT480	1
8	Washer - sealing	UBF93	4	UBF93	4	UBF93	4	UBF93	4	UBF93	4
21	Endcover - input shaft	CP1224	4	CP1224	4	CP1224	4	CP1224	4	CP1224	4
22	Screw - endcover	MT318	1	MT318	1	MT374	1	MT374	1	MT374	1
8	Washer - sealing	USF33	2	USF33	2	USF33	3	USF33	3	USF33	3
23	Flange - output	CP1224	2	CP1224	2	CP1224	3	CP1224	3	CP1224	3
24	Washer - plain	MT753*	1	MT753*	1	MT755	1	MT755	1	MT755	1
25	Nut - locking	MT600	1	MT600	1	MT664	1	MT664	1	MT664	1
		MT689	1	MT689	1	MT690	1	MT690	1	MT690	1

↳ Replaced by 0061210

NOTE: The Part Number for the gearcase sub-assembly of horizontally mounted PRM265 gearboxes is MT874. This comprises the standard top half of the gearcase (MT215), a special lower gearcase (MT869), 1-MT848 oil shroud (fitted internally), 1-MT849 oil shroud (fitted internally), 2-0020204 screws and 2-CP1294 washers, in addition to the standard bolts, washers, studs and nuts used for securing the two gearcase halves together.

* If the output flange has a male spigot please use part no. MT754.

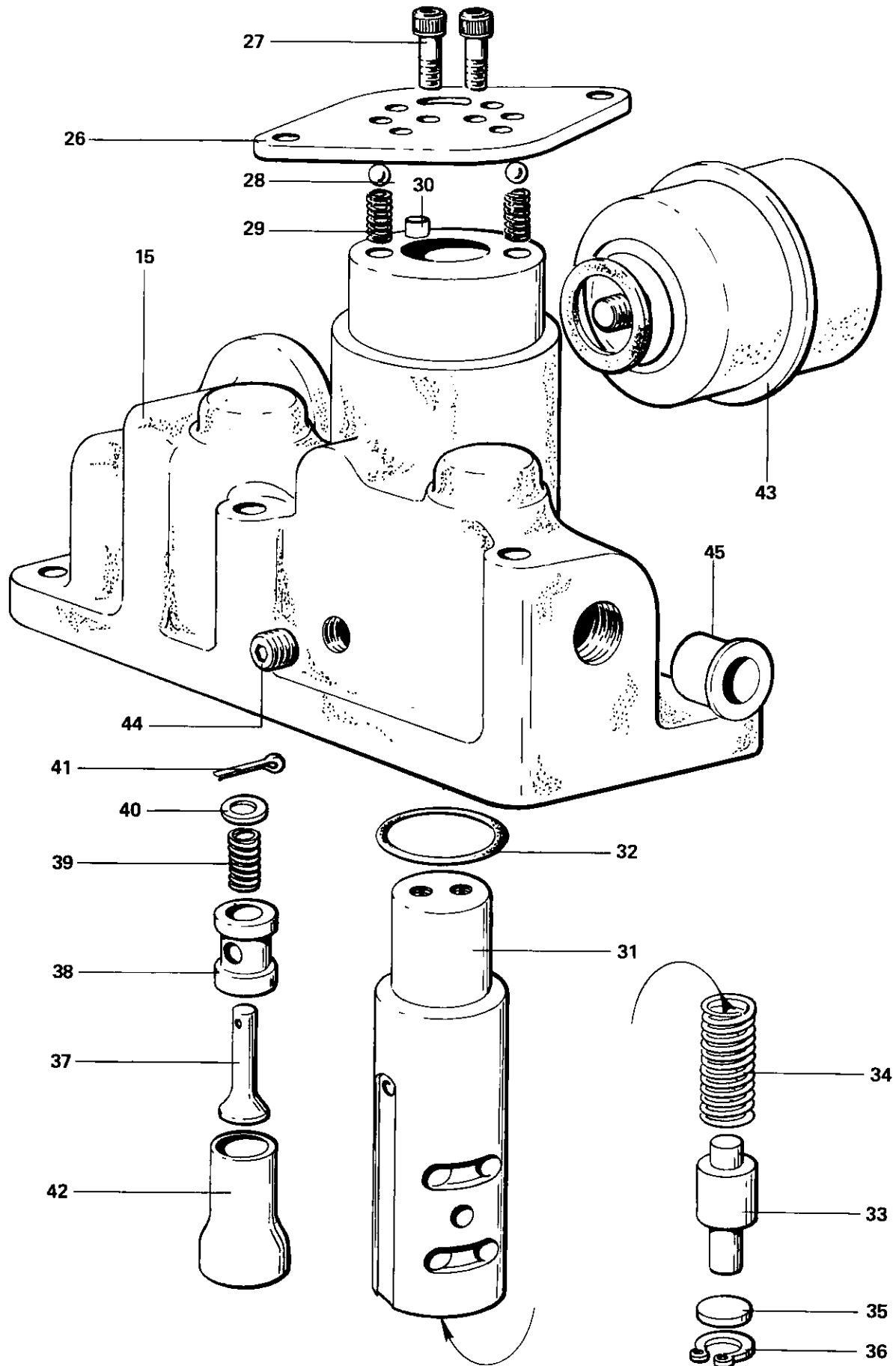

Fig. 12 Valve Block Assembly

PARTS LIST

Plate Ref.	Description	PRM100 Part No.	Qty	PRM140 Part No.	Qty	PRM175 Part No.	Qty	PRM250 Part No.	Qty	PRM265 Part No.	Qty
26	LEVER - operating	MT678	1	MT678	1	MT678	1	MT678	1	MT678	1
27	Screw - lever	UFC410	2	UFC410	2	UFC410	2	UFC410	2	UFC410	2
28	Detent ball	CP1077	2	CP1077	2	CP1077	2	CP1077	2	CP1077	2
29	Detent spring	MT685	2	MT685	2	MT685	2	MT685	2	MT685	2
30	Stop pin - lever	CP1101	1	CP1101	1	CP1101	1	CP1101	1	CP1101	1
31	VALVE ASSEMBLY - control	MT699	1	MT699	1	MT699	1	MT699	1	MT699	1
32	CONTROL VALVE	MT676	1	MT676	1	MT676	1	MT676	1	MT676	1
33	'O' ring	0,01313	1	0,01313	1	0,01313	1	0,01313	1	0,01313	1
34	RELIEF VALVE	MT302	1	MT302	1	MT302	1	MT302	1	MT302	1
35	Valve spring - relief	MT446	1	MT446	1	MT446	1	MT446	1	MT446	1
36	Valve stop - relief	MT308	1	MT308	1	MT308	1	MT308	1	MT308	1
	Circlip	MT312	1	MT312	1	MT312	1	MT312	1	MT312	1
	VALVE ASSEMBLY - Pressure										
	Differential	MT696	2	MT696	2	MT696	2	MT696	2	MT696	2
37	Valve - pressure differential	MT303	2	MT303	2	MT303	2	MT303	2	MT303	2
38	Seat - valve	MT304	2	MT304	2	MT304	2	MT304	2	MT304	2
39	Spring - valve	MT305	2	MT305	2	MT305	2	MT305	2	MT305	2
40	Washer - plain	W128	2	W128	2	W128	2	W128	2	W128	2
41	Pin - split	40M/244	2	40M/244	2	40M/244	2	40M/244	2	40M/244	2
42	Retaining sleeve	MT686	2	MT686	2	MT686	2	MT686	2	MT686	2
43	FILTER - OIL	MT279	1	MT279	1	MT279	1	MT279	1	MT279	1
44	Plug - pressure	MT311	3	MT311	3	MT311	3	MT311	3	MT311	3
45	Seal - Redcap - for transit only	MT477	2	MT477	2	MT477	2	MT477	2	MT477	2

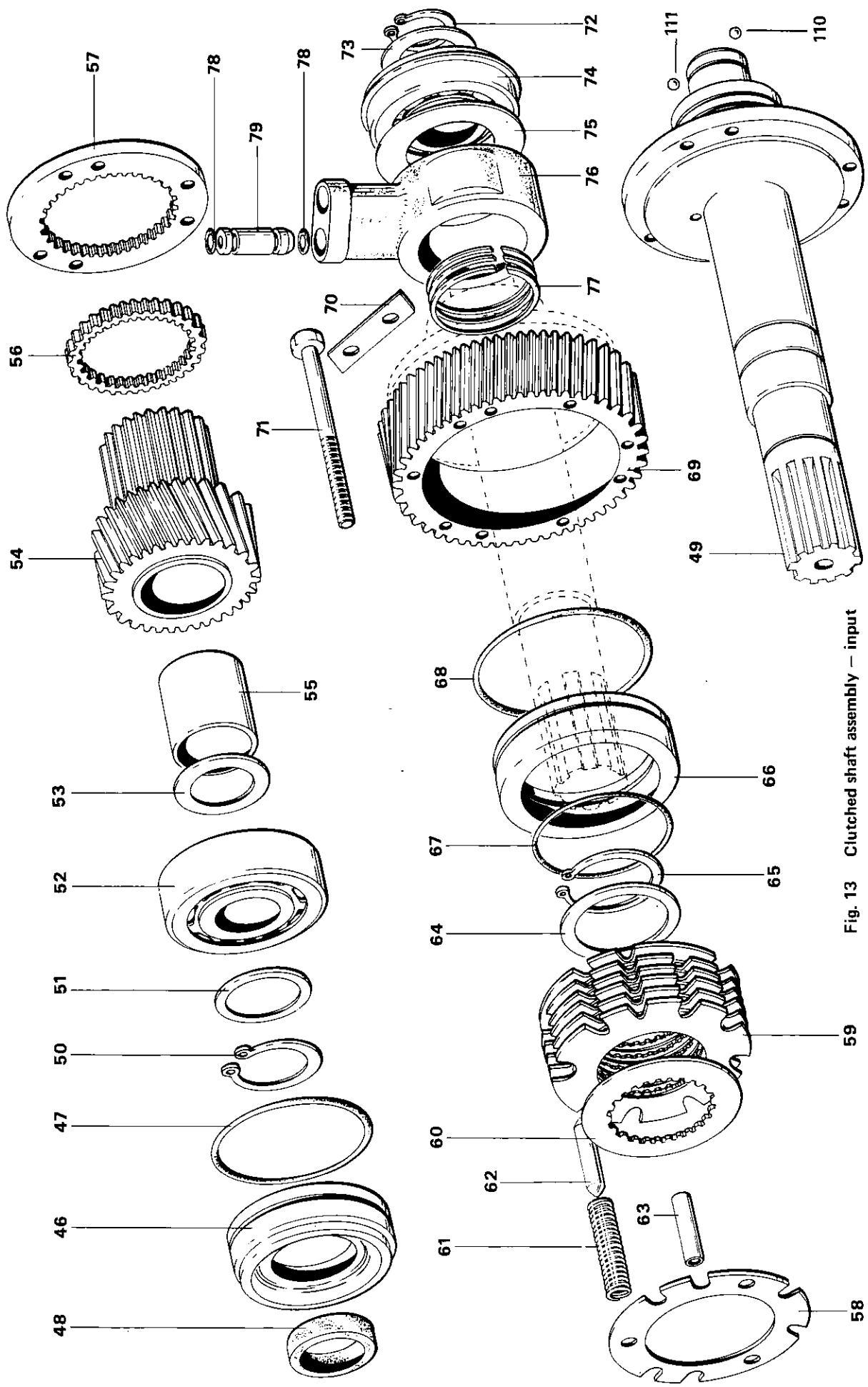

Fig. 13 Clutched shaft assembly — input

PARTS LIST

Plate Ref.	Description	PRM100 Part No.	Qty	PRM175 Part No.	Qty	PRM250 Part No.	Qty
46	End housing - input	MT317	1	MT382	1	MT382	1
47	'O' ring	0,02433	1	0,02874	1	0,02874	1
48	Oil seal	MT165	1	MT251	1	MT251	1
49	CLUTCHED SHAFT ASSEMBLY INPUT (gearbox with R.H. output rotation)	MT481	1	MT483	1	MT409	1
110	INPUT SHAFT (gearbox with L.H. output rotation)	MT667	1	MT665	1	MT666	1
111	Ball	MT340	1	MT390	1	MT390	1
50	Ball	CP1191	1	CP1191	1	CP1191	1
51	Circlip	CP1180	1	CP1180	1	CP1180	1
52	Spacer	CP1096	1	CM2053	1	CM2053	1
53	BEARING - ROLLER - drive end	MT336	1	MT419	1	MT419	1
54	Spacer	T7023	1	MT412	1	MT412	1
55	PINION - DRIVE - 3:1 ratio	MT350	1	MT386	1	MT386	1
56	(Assembly)	MT732	1	MT739	1	MT739	1
57	Bush (fitted in assembly)	MT733	1	MT740	1	MT740	1
58	Splined ring *	MT734	1	MT741	1	MT741	1
59	CLUTCH END COVER - splined	MT361	2	MT416	2	MT416	2
60	PLATE ASSEMBLY - CLUTCH - Supplied as a complete assembly	MT334	1	MT395	1	MT395	1
61	Clutch end plate	MT335	1	MT394	1	MT394	1
62	Clutch plate - driven	MT698	1	MT694	1	MT695	1
63	Clutch plate - driver	MT117	2	MT214	2	MT214	2
64	Spring - pull-off	MT116	5	MT212	6	MT212	6
65	Pin - spring	MT118	6	MT213	7	MT488	7
66	Ferrule	MT120	3	MT293	3	MT293	3
67	Spacer	MT357	3	MT418	3	MT418	3
68	Circlip	MT115	6	MT234	6	MT234	6
69	PISTON	MT344	1	MT387	1	MT387	1
70	Step joint - piston ring	CP1102	1	CM2067	1	CM2067	1
71	Step joint - piston ring	MT345	1	MT389	1	MT389	1
72	CLUTCH GEAR R.H.	MT358	1	MT369	1	MT369	1
73	Tab strip	MT359	1	MT370	1	MT370	1
74	Bolt - clutch securing	MT333	1	MT397	1	MT397	1
75	Circlip	MT351	3	MT411	3	MT411	3
76	Spacer	MT452	6	MT456	6	MT456	6
77	BEARING - BALL - non-drive end	CP1096	1	CM2067	1	CM2067	1
78	Spacer	MT336	1	MT385	1	MT385	1
79	FEEDER	MT160	1	MT404	1	MT404	1
80	Piston ring	MT337	1	MT384	1	MT384	1
81	'O' ring	MT315	1	MT380	1	MT380	1
82	Connector - feeder	CP1192	3	MT292	3	MT292	3
83		0,00372	4	0,00372	4	0,00372	4
84		MT352	2	MT352	2	MT352	2

* Only fitted on MT481, MT483, MT409, MT872 and MT875.

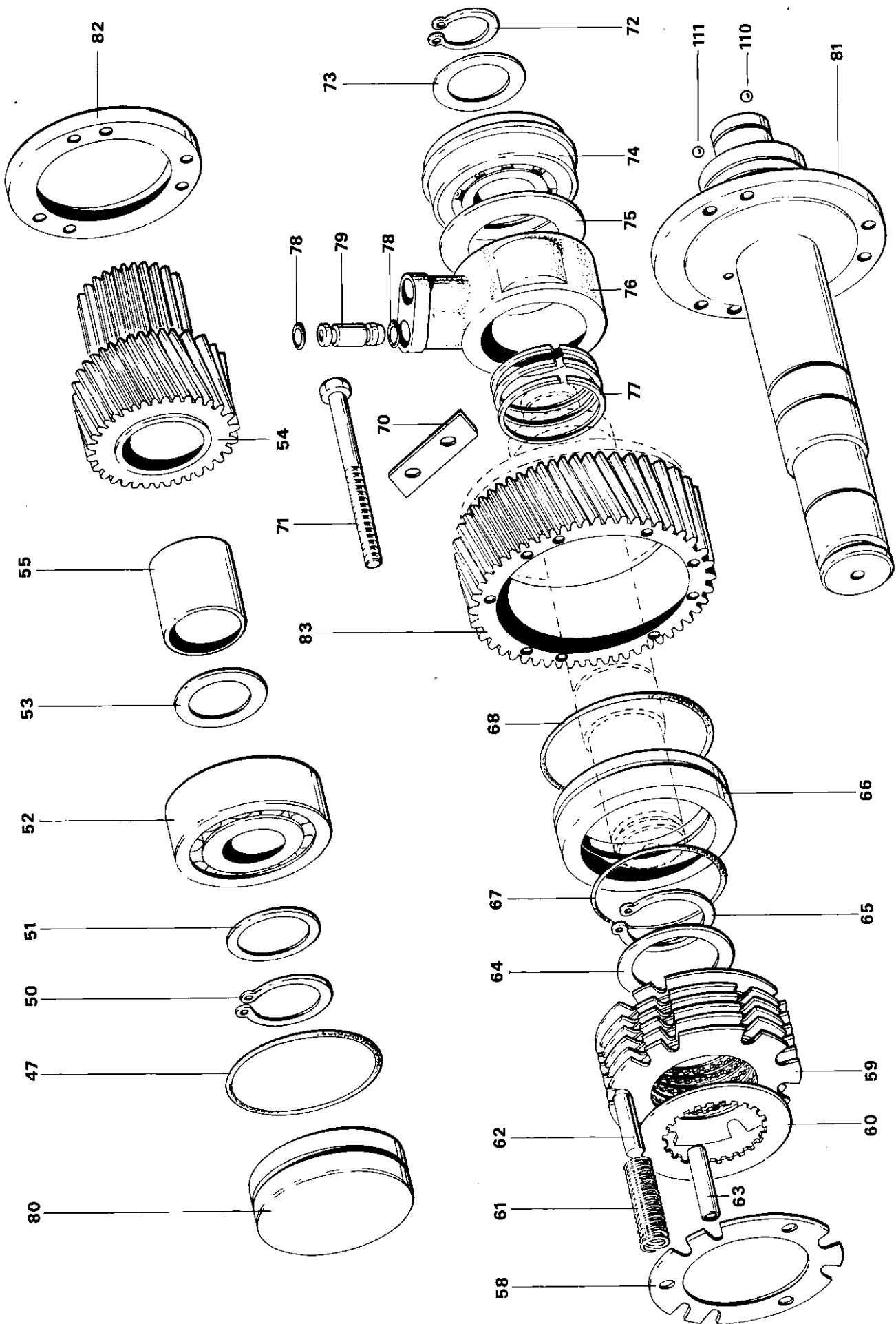

Fig. 14 Clutched shaft assembly — layshaft

PARTS LIST

Plate Ref.	Description	PRM100 Part No.	Qty	PRM175 Part No.	Qty	PRM250 Part No.	Qty
80	End cover	MT316	1	MT383	1	MT383	1
47	'O' ring	0,02433	1	0,02874	1	0,02874	1
	CLUTCHED SHAFT ASSEMBLY - IDLER (R.H. output rotation)						
	(L.H. output rotation)						
81	LAYSHAFT	MT482	1	MT484	1	MT489	1
110	Ball	MT608	1	MT609	1	MT610	1
111	Ball	MT339	1	MT391	1	MT391	1
50	Circlip - bearing	CP1191	1	CP1191	1	CP1191	1
51	Spacer	CP1180	1	CP1180	1	CP1180	1
52	BEARING - ROLLER - drive end	CP1096	1	CM2053	1	CM2053	1
53	Spacer	MT336	1	MT419	1	MT419	1
54	PINION - DRIVE - 3:1 ratio (Assembly)	T7023	1	MT412	1	MT412	1
	2:1 ratio	MT350	1	MT386	1	MT386	1
	1:1 ratio	MT732	1	MT739	1	MT739	1
	Bush (fitted in assembly)	MT733	1	MT740	1	MT740	1
	Spined ring *	MT734	1	MT741	1	MT741	1
82	Clutch end cover - plain PLATE ASSEMBLY - Clutch - Supplied as a complete assembly	MT361	2	MT416	2	MT416	2
	Clutch end plate	MT334	1	MT395	1	MT395	1
	Clutch plate - driven	MT338	1	MT393	1	MT393	1
	Clutch plate - driver						
58	Spring - pull-off	MT693	1	MT694	1	MT695	1
59	Pin - spring	MT117	2	MT214	2	MT214	2
60	Ferrule	MT116	5	MT212	6	MT212	6
61	Spacer	MT118	6	MT213	7	MT488	7
62	Circlip	MT120	3	MT293	3	MT293	3
63	PISTON	MT357	3	MT418	3	MT418	3
64	Step joint - piston ring	MT115	6	MT234	6	MT234	6
65	Step joint - piston ring	MT344	1	MT387	1	MT387	1
66	Step joint - piston ring	CP1102	1	CM2067	1	CM2067	1
67	Step joint - piston ring	MT345	1	MT389	1	MT389	1
68	Step joint - piston ring	MT358	1	MT369	1	MT369	1
83	CLUTCH GEAR L.H.	MT359	1	MT370	1	MT370	1
70	Tab strip	MT332	1	MT396	1	MT396	1
71	Bolt - clutch securing	MT351	3	MT411	3	MT411	3
72	Circlip	MT452	6	MT456	6	MT456	6
73	Spacer	CP1096	1	CM2067	1	CM2067	1
74	BEARING - BALL - non-drive end	MT336	1	MT385	1	MT385	1
75	Spacer	MT160	1	MT404	1	MT404	1
76	FEEDER	MT337	1	MT384	1	MT384	1
77	Piston ring	MT315	1	MT380	1	MT380	1
78	'O' ring	CP1192	3	MT292	3	MT292	3
79	Connector feeder	0,00372	4	0,00372	4	0,00372	4
		MT352	2	MT352	2	MT352	2

MT 0199/3 replaced

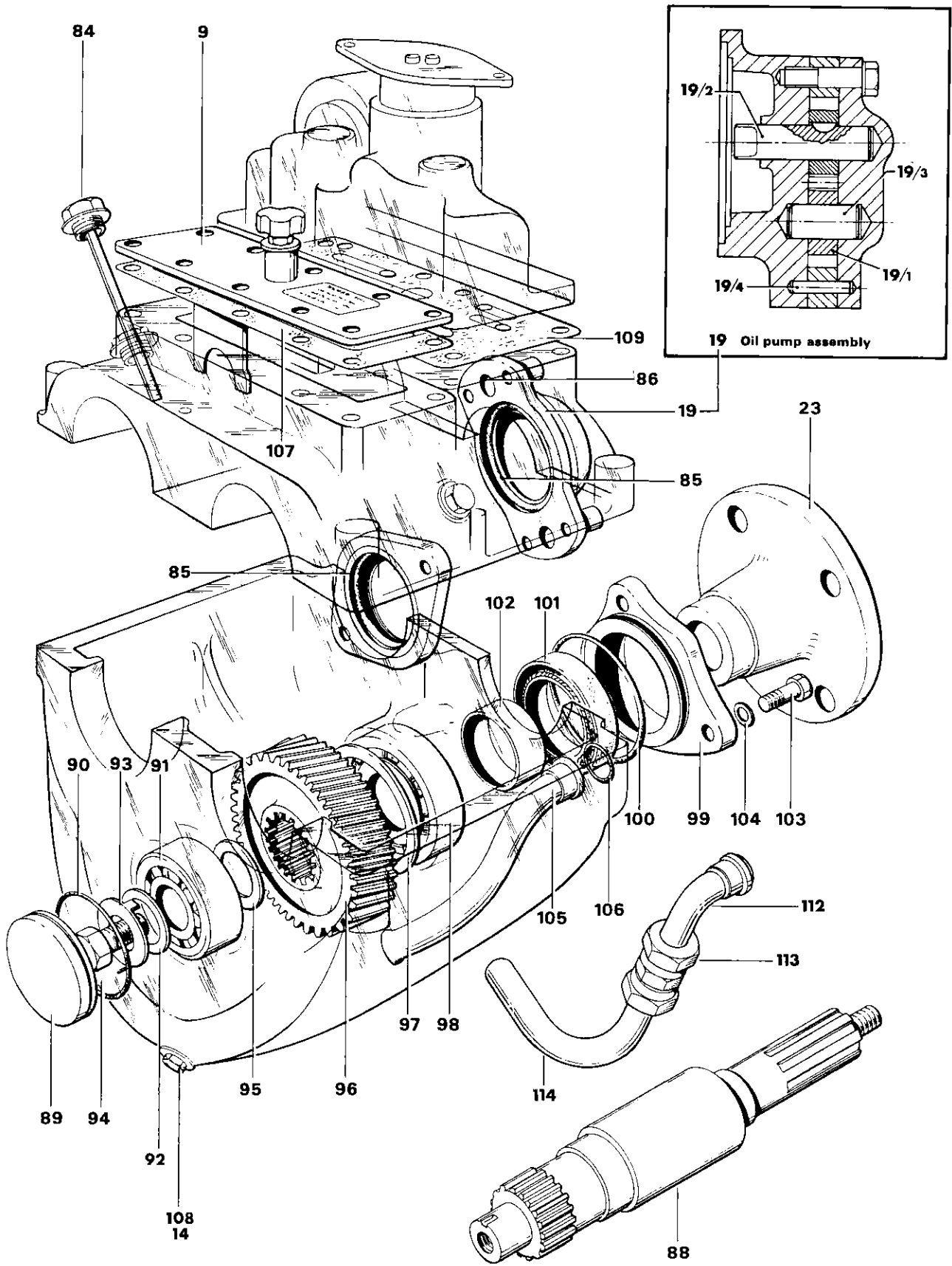

Fig. 15 Gearcase and output shaft assembly

PARTS LIST

Plate Ref.	Description	PRM100 Part No.	Qty	PRM140 Part No.	Qty	PRM175 Part No.	Qty	PRM250 Part No.	Qty	PRM265 Part No.	Qty
84	Dipstick/Filler - Vertical	MT471	1	MT471	1	MT472	1	MT472	1	MT472	1
19	Dipstick/Filler - Horizontal PUMP ASSEMBLY - Oil - supplied complete	MT485	1	MT485	1	MT486	1	MT486	1	0800925	1
19/1	Gear - driven	MT479	1	MT479	1	MT480	1	MT480	1	MT480	1
19/2	Spindle - driver (Sub-Assembly)	MT323	1	MT323	1	MT379	1	MT379	1	MT379	1
19/3	Spindle - driven	MT903	1	MT903	1	MT904	1	MT904	1	MT904	1
19/4	Dowel	MT325	1	MT325	1	MT378	1	MT378	1	MT378	1
85	'O' ring	MT356	2	MT356	2	MT417	2	MT417	2	MT417	2
86	'O' ring - pump to casing	0,02873	2	0,02873	2	0,03383	2	0,03383	2	0,03383	2
	'O' ring - valve block to casing	0,01254	1	0,01254	1	0,01254	1	0,01254	1	0,01254	1
	'O' ring - valve block to casing	0,00623	1	0,00623	1	0,00623	1	0,00623	1	0,00623	1
88	OUTPUT SHAFT	MT346	1	MT721	1	MT392	1	MT392	1	MT723	1
89	End cover	MT429	1	MT429	1	MT430	1	MT430	1	MT430	1
90	'O' ring	0,02063	1	0,02063	1	0,02433	1	0,02433	1	0,02433	1
91	BEARING - Roller - forward	MT360	1	0532023	1	MT406	1	MT714	1	0533021	1
92	Washer - bearing retaining	MT428	1	MT428	1	MT423	1	MT423	1	MT423	1
93	Washer - Tab/shakeproof	MT425	1	MT425	1	MT489	1	MT489	1	MT489	1
94	Screw	USF33	1	USF33	1	USF12	2	USF12	2	USF12	2
95	Spacer	MT353	1	MT353	1	MT716	1	MT716	1	MT716	1
96	OUTPUT GEAR 3:1 1.5:1	MT327	1	MT327	1	MT401	1	MT401	1	MT720	1
										MT893	1
										MT719	1
										MT718	1
97	Circlip - bearing	MT329	1	MT329	1	MT402	1	MT402	1	MT719	1
		MT331	1	MT331	1	MT400	1	MT400	1	MT718	1
98	BEARING - Ball - drive end	CP1190	1	CP1190	1	CP1194	1	CP1194	1	CP1194	1
99	End housing - output	A15	1	MT711	1	MT405	1	MT451	1	MT451	1
100	'O' ring	MT319	1	MT319	1	MT375	1	MT375	1	MT375	1
		0,03504	1	0,03504	1	0,04754	1	0,04754	1	0,04754	1
101	Seal	MT349	1	MT349	1	MT252	1	MT252	1	MT252	1
102	Spacer			MT715	1					MT717	1
103	Bolt - end housing	UBF53	3	UBF53	3	UBF63	4	UBF63	4	UBF63	4
104	Washer	W108	3	W108	3	W108	4	W108	4	W108	4
105	Oil pipe - standard	MT736	1	MT736	1	MT736	1	MT736	1	MT736	1
		MT737	1	MT737	1	MT744	1	MT744	1	MT744	1
106	Oil pipe - short	MT736	1	MT736	1	MT744	1	MT744	1	MT744	1
		0,01254	1	0,01254	1	0,01254	1	0,01254	1	0,01254	1
107	Joint - top cover	MT343	1	MT343	1	MT343	1	MT343	1	MT343	1
108	Plug - flanged - drain	CP1268	1	CP1268	1	CP1268	1	CP1268	1	CP1268	1
14	Washer - sealing	CP1068	1	CP1068	1	CP1068	1	CP1068	1	CP1068	1
109	Joint - valve block	MT313	1	MT313	1	MT313	1	MT313	1	MT313	1
114	Oil Pipe Extension *									MT907 *	1
112	Oil Pipe *									MT908 *	1
113	Adaptor *									CP1297 *	1

* NOTE: Part Numbers MT907, MT908 and CP1297 replace MT736 on model PRM265 (HR) only.

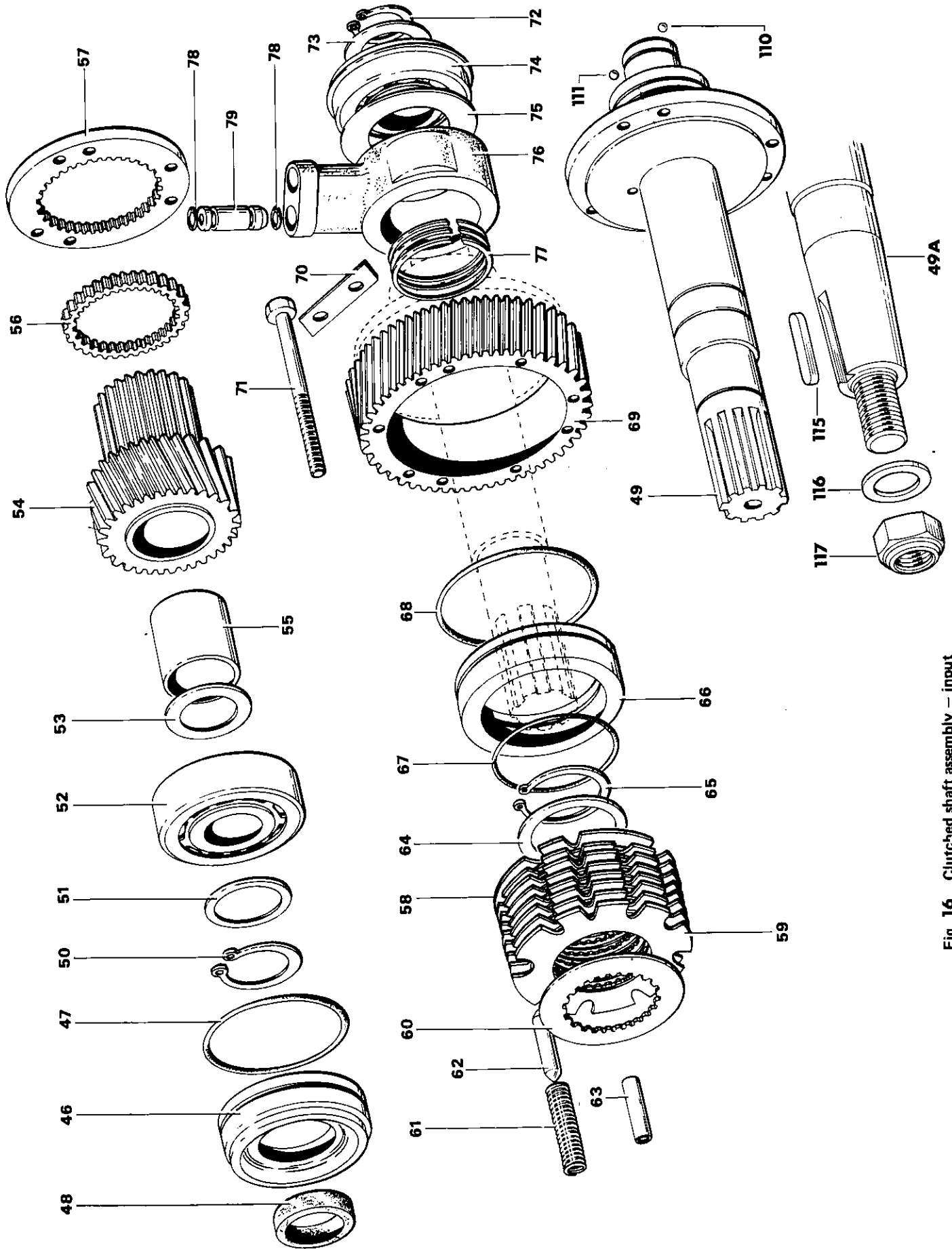

Fig. 16 Clutched shaft assembly — input

PARTS LIST

Plate Ref.	Description	PRM140 Part No.	Qty	PRM265 Part No.	Qty
46	End housing - input	MT317	1	MT382	1
47	'O' ring	0,02433	1	0,02874	1
48	Oil seal	MT165	1	MT251	1
	CLUTCHED SHAFT ASSEMBLY				
	INPUT				
	(gearbox with R.H. output rotation)	MT875	1	MT872	1
	(gearbox with L.H. output rotation)	MT876	1	MT873	1
49	INPUT SHAFT - Splined	MT340	1	MT390	1
49A	INPUT SHAFT - Tapered * *	MT749 RH MT752 LH	1	MT745 RH MT747 LH	1
110	(Assembly)				
	Ball	CP1191	1	CP1191	1
111	Ball	CP1180	1	CP1180	1
50	Circlip	CP1096	1	CM2053	1
51	Spacer	MT336	1	MT419	1
52	BEARING - ROLLER - drive end	T7023	1	0533026	1
53	Spacer	MT350	1	MT386	1
54	PINION - DRIVE - 3:1 ratio	MT732	1	MT722 <i>MT 0 N 6/13</i>	1
	(Assembly)				
	1.5:1 ratio	MT733	1	MT894	1
	2:1 ratio	MT740	1	MT740	1
	1:1 ratio	MT734	1	MT741	1
55	Bush (fitted in assembly)	MT361	2	MT416	2
56	Splined ring *	MT334	1	MT395	1
57	CLUTCH END COVER - splined	MT727	1	MT729	1
	PLATE ASSEMBLY - CLUTCH - Supplied as a complete assembly				
58	Clutch end plate	MT813	1	MT814	1
59	Clutch plate - driven	MT117	1	MT214	1
60	Clutch plate - driver	MT116	7	MT212	8
61	Spring - pull-off	MT731	8	MT725	9
62	Pin - spring	MT120	3	MT293	3
63	Ferrule	MT357	3	MT418	3
64	Spacer	MT730	6	MT234	6
65	Circlip	MT344	1	MT387	1
66	PISTON	CP1102	1	CM2067	1
67	Step joint - piston ring	MT345	1	MT389	1
68	Step joint - piston ring	MT358	1	MT369	1
69	CLUTCH GEAR R.H.	MT359	1	MT370	1
70	Tab strip	MT333	1	MT397	1
71	Bolt - clutch securing	MT351	3	MT411	3
72	Circlip	MT452	6	MT456	6
73	Spacer	CP1096	1	CM2067	1
74	BEARING - BALL - non-drive end	MT336	1	MT385	1
75	Spacer	MT160	1	MT404	1
76	FEEDER	MT337	1	MT384	1
77	Piston ring	MT315	1	MT380	1
78	'O' ring	CP1192	3	MT292	3
79	Connector - feeder	0,00372	4	0,00372	4
115	Key	MT352	2	MT352	2
116	Washer	MT760	1	MT761	1
117	Nut	CP1289 UN521	1	CP1288 UN544	1

* Only fitted on MT481, MT483, MT409, MT872 and MT875.

* * If gearbox is fitted with a tapered input shaft use part nos. MT722 (PRM140T) or MT724 (PRM265T). Both shafts should be fitted with a key MT760 (PRM140T) or MT761 (PRM265T), washer CP1289 (PRM140T) or CP1288 (PRM265T) and nut UN521 (PRM140T) or UN544 (PRM265T)

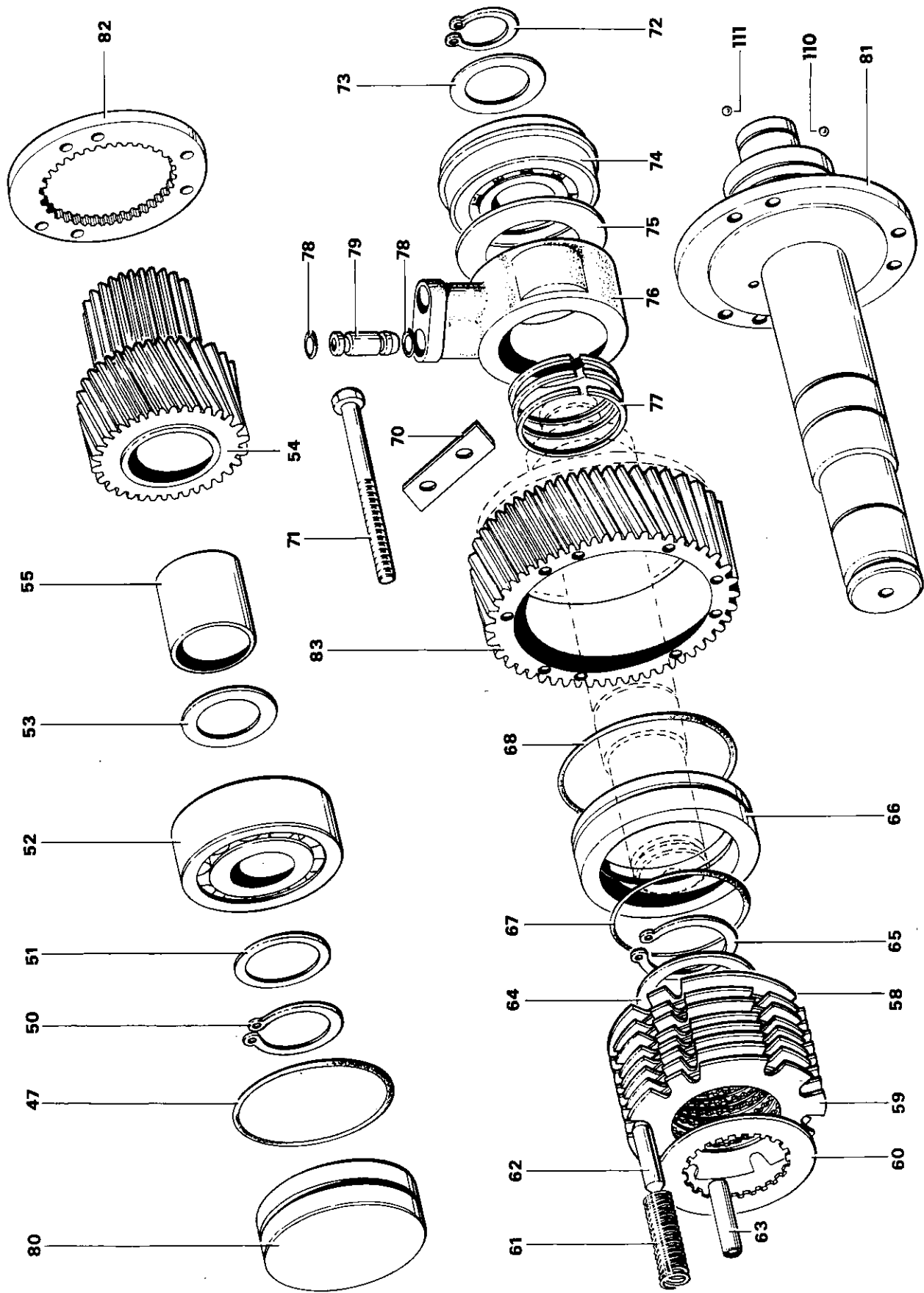

Fig. 17 Clutched shaft assembly — layshaft

PARTS LIST

Plate Ref.	Description	PRM140 Part No.	Qty	PRM265 Part No.	Qty
80	End cover	MT316	1	MT383	1
47	'O' ring	0,02433	1	0,02874	1
	CLUTCHED SHAFT ASSEMBLY - IDLER (R.H. output rotation)				
	(L.H. output rotation)				
81	LAYSHAFT	MT750	1	MT746	1
110	Ball	MT751	1	MT748	1
111	Ball	MT339	1	MT391	1
	Ball	CP1191	1	CP1191	1
	Ball	CP1180	1	CP1180	1
50	Circlip - bearing	CP1096	1	CM2053	1
51	Spacer	MT336	1	MT419	1
52	BEARING - ROLLER - drive end	T7023	1	0533026	1
53	Spacer	MT350	1	MT386	1
54	PINION - DRIVE - 3:1 ratio (Assembly)	MT732	1	MT739	1
	2:1 ratio	MT733	1	MT740	1
	1:1 ratio	MT734	1	MT741	1
55	Bush (fitted in assembly)	MT361	2	MT416	2
	Spined ring *	MT334	1	MT395	1
82	Clutch end cover - spined	MT726	1	MT728	1
	PLATE ASSEMBLY - Clutch - Supplied as a complete assembly				
58	Clutch end plate	MT117	1	MT214	1
59	Clutch plate - driven	MT116	7	MT212	8
60	Clutch plate - driver	MT731	8	MT725	9
61	Spring - pull-off	MT120	3	MT293	3
62	Pin - spring	MT357	3	MT418	3
63	Ferrule	MT730	6	MT234	6
64	Spacer	MT344	1	MT387	1
65	Circlip	CP1102	1	CM2067	1
66	PISTON	MT345	1	MT389	1
67	Step joint - piston ring	MT358	1	MT369	1
68	Step joint - piston ring	MT359	1	MT370	1
83	CLUTCH GEAR L.H.	MT332	1	MT396	1
70	Tab strip	MT351	3	MT411	3
71	Bolt - clutch securing	MT452	6	MT456	6
72	Circlip	CP1096	1	CM2067	1
73	Spacer	MT336	1	MT385	1
74	BEARING - BALL - non-drive end	MT160	1	MT404	1
75	Spacer	MT337	1	MT384	1
76	FEEDER	MT315	1	MT380	1
77	Piston ring	CP1192	3	MT292	3
78	'O' ring	0,00372	4	0,00372	4
79	Connector feeder	MT352	2	MT352	2

* Only fitted on MT608, MT609, MT610, MT751 and MT748

